

ASME B18.2.2-2015
(Revision of ASME B18.2.2-2010)

Nuts for General Applications: Machine Screw Nuts, Hex, Square, Hex Flange, and Coupling Nuts (Inch Series)

AN AMERICAN NATIONAL STANDARD



**The American Society of
Mechanical Engineers**

ASME B18.2.2-2015
(Revision of ASME B18.2.2-2010)

Nuts for General Applications: Machine Screw Nuts, Hex, Square, Hex Flange, and Coupling Nuts (Inch Series)

AN AMERICAN NATIONAL STANDARD



**The American Society of
Mechanical Engineers**

Two Park Avenue • New York, NY • 10016 USA

Date of Issuance: November 30, 2015

This Standard will be revised when the Society approves the issuance of a new edition.

ASME issues written replies to inquiries concerning interpretations of technical aspects of this Standard. Interpretations are published on the Committee Web page and under go.asme.org/InterpsDatabase. Periodically certain actions of the ASME B18 Committee may be published as Cases. Cases are published on the ASME Web site under the B18 Committee Page at go.asme.org/B18committee as they are issued.

Errata to codes and standards may be posted on the ASME Web site under the Committee Pages to provide corrections to incorrectly published items, or to correct typographical or grammatical errors in codes and standards. Such errata shall be used on the date posted.

The B18 Committee Page can be found at go.asme.org/B18committee. There is an option available to automatically receive an e-mail notification when errata are posted to a particular code or standard. This option can be found on the appropriate Committee Page after selecting "Errata" in the "Publication Information" section.

ASME is the registered trademark of The American Society of Mechanical Engineers.

This code or standard was developed under procedures accredited as meeting the criteria for American National Standards. The Standards Committee that approved the code or standard was balanced to assure that individuals from competent and concerned interests have had an opportunity to participate. The proposed code or standard was made available for public review and comment that provides an opportunity for additional public input from industry, academia, regulatory agencies, and the public-at-large.

ASME does not "approve," "rate," or "endorse" any item, construction, proprietary device, or activity.

ASME does not take any position with respect to the validity of any patent rights asserted in connection with any items mentioned in this document, and does not undertake to insure anyone utilizing a standard against liability for infringement of any applicable letters patent, nor assumes any such liability. Users of a code or standard are expressly advised that determination of the validity of any such patent rights, and the risk of infringement of such rights, is entirely their own responsibility.

Participation by federal agency representative(s) or person(s) affiliated with industry is not to be interpreted as government or industry endorsement of this code or standard.

ASME accepts responsibility for only those interpretations of this document issued in accordance with the established ASME procedures and policies, which precludes the issuance of interpretations by individuals.

No part of this document may be reproduced in any form,
in an electronic retrieval system or otherwise,
without the prior written permission of the publisher.

The American Society of Mechanical Engineers
Two Park Avenue, New York, NY 10016-5990

Copyright © 2015 by
THE AMERICAN SOCIETY OF MECHANICAL ENGINEERS
All rights reserved
Printed in U.S.A.

CONTENTS

Foreword	iv
Committee Roster	vii
Correspondence With the B18 Committee	viii
1 Introduction	1
2 References.....	1
3 General Data.....	1
Tables	
1-1 Dimensions of Square and Hex Machine Screw Nuts	4
1-2 Dimensions of Small Pattern Hex Machine Screw Nuts	5
2 Dimensions of Square Nuts	6
3 Dimensions of Hex Flat Nuts and Hex Flat Jam Nuts	7
4 Dimensions of Hex Nuts and Hex Jam Nuts	8
5 Dimensions of Hex Slotted Nuts	9
6 Dimensions of Hex Thick Nuts	10
7 Dimensions of Hex Thick Slotted Nuts	11
8 Dimensions of Heavy Square Nuts	12
9 Dimensions of Heavy Hex Flat Nuts and Heavy Hex Flat Jam Nuts	13
10 Dimensions of Heavy Hex Nuts and Heavy Hex Jam Nuts	14
11 Dimensions of Heavy Hex Slotted Nuts	15
12 Dimensions of Hex Flange Nuts and Large Hex Flange Nuts	16
13 Dimensions of Hex Coupling Nuts	17
Mandatory Appendix	
I Slot Gages and Gaging for Slotted Nuts	19
Nonmandatory Appendices	
A Formulas for Nut Dimensions	21
B Wrench Openings for Square and Hex Nuts	24
C Procedure for Measuring Bearing Surface Runout	26

FOREWORD

American National Standards Committee B18 for the standardization of bolts, screws, nuts, rivets, and similar fasteners was organized in March 1922 as Sectional Committee B18 under the aegis of the American Engineering Standards Committee (later the American Standards Association, then the United States of America Standards Institute, Inc.) with the Society of Automotive Engineers and the American Society of Mechanical Engineers as joint sponsors. Subcommittee 2 was subsequently established and charged with the responsibility for technical content of standards covering wrench head bolts and nuts.

Subcommittee 2, after appraisal of the requirements of industry, developed a proposed standard series of bolt head and nut dimensions. This proposal was finally approved and designated a Tentative American Standard in February 1927.

A first revision of the document was designated as an American Standard in March 1933 and was followed by a second revision that was granted approval as an American Standard in January 1941.

Following reorganization of the B18 Committee in 1947, Subcommittee 2 was asked to expand the standard on head proportions into a complete product standard. A proposal covering square and hexagon head bolts and nuts, hexagon head cap screws, and automotive hexagon head bolts was prepared and submitted to the B18 Committee in April 1950. While this draft was under consideration, the B18 Committee received a proposal from the British Standards Institution for unification of dimensions on products incorporating unified screw threads. The Committee welcomed the opportunity of discussing the proposals and an American-British-Canadian Conference was held in New York on June 1 and 2, 1950.

It was agreed in the conference that the essentials of unification could be accomplished by selection of mutually satisfactory across-the-flats dimensions, since this would permit the use of the same wrenches and because other features would rarely affect interchangeability. After due consideration, suitable existing across-the-flats dimensions were selected for the hexagon products affected.

In its meeting of October 13, 1950, Subcommittee 2 agreed to incorporate into the proposed standard the conference recommendations on $\frac{1}{4}$ in. hexagon head bolts, $\frac{5}{8}$ in. hexagon head cap screws and automotive hexagon head bolts, and $\frac{7}{16}$ in. light and regular hexagon and square nuts. At a subsequent meeting of Subcommittee 2, further changes were adopted in order to combine the light and regular series of nuts, and to combine the automotive hexagon head bolt, hexagon head cap screw, and regular hexagon head close tolerance bolt.

In view of the progress made in the United States and the urgency of standardization for mutual defense, the British Standards Institution sponsored a second conference in London in April 1951 to complete the unification of certain hexagon bolts and nuts.

At a meeting on June 8, 1951, Subcommittee 2 reaffirmed its acceptance of the unified dimensions that correspond with those in the March 1951 draft, but attempted to select better nomenclature for the unified products. A final draft incorporating the nomenclature "Finished Hexagon Bolts and Nuts" and containing numerous editorial changes was submitted for letter ballot in September 1951. Following approval by the B18 Committee and the sponsors, the proposal was presented to the American Standards Association for approval and designation as an American Standard. This was granted on March 24, 1952.

It was recognized that the standard was in need of additional refinements, therefore Subcommittee 2 began work immediately to eliminate these shortcomings. A proposed revision removing inconsistencies with respect to fillets, improving the length tolerances on heavy hexagon bolts, and incorporating numerous other corrections and clarifications of an editorial nature resulted. The most noteworthy editorial change was a decision to combine the coverage for hexagon cap screws and square head set screws from the B18.2 standard with the coverage for slotted head cap screws and slotted headless set screws from the B18.6 standard for publication in a separate document. The requirements for the unified hexagon cap screws and finished

hexagon bolts being identical in the overlapping sizes, the data would now be available in two publications. Following approvals by the B18 Committee and sponsor organizations, the proposal was submitted to the American Standards Association and declared an American Standard on February 2, 1955.

A revision of this Standard comprised of numerous editorial corrections and inclusion of an appendix for grade markings was duly approved and designated an American Standard on April 18, 1960.

At a meeting in February 1960, Subcommittee 2 approved a recommendation to reduce the head heights for heavy, heavy semifinished, and heavy finished hexagon bolt, which was subsequently approved by letter ballot of the B18 Committee on August 16, 1960. A proposed standard for heavy hexagon structural bolts submitted and accepted by Subcommittee 2 at its October 17, 1960 meeting was approved by letter ballot of the B18 Committee on May 9, 1961. To meet the urgent needs of the steel construction industry, it was considered necessary to publish the standard for the structural bolts immediately. Consequently, Appendix IV to ASA B18.2-1960 containing coverage for the revised heavy hexagon bolts and the new heavy hexagon structural bolts was released in 1962.

In October 1961, Subcommittee 2 appointed a subgroup to review all product standards for square and hexagon bolts, screws, and nuts, and to recommend simplifications that would be compatible with technical, production, and distribution advances that had occurred over the prior several years. The subgroup presented its recommendations at a meeting of Subcommittee 2 in October 1962. It was agreed that the internally and externally threaded products should be published in separate documents as suggested, and draft proposals for each were completed.

The proposed revision for square and hex nuts incorporated the following subgroup recommendations: discontinuation of regular semifinished nuts; elimination of regular hexagon and heavy hexagon nuts in sizes $\frac{1}{4}$ in. through 1 in.; elimination of finished hexagon nuts in sizes larger than $1\frac{1}{2}$ in.; elimination of the washer face semifinished style on finished series nuts in sizes $\frac{5}{8}$ in. and smaller and heavy series nuts in sizes $\frac{7}{16}$ in. and smaller; removal of machine screw nuts (these nuts are now contained in B18.6.3); and adoption of an abbreviated product nomenclature. Letter ballot of this proposal to the B18 Committee resulted in approval. Following acceptance by the sponsor organizations the revision was submitted to the American Standards Association and designated ASA B18.2.2 on September 8, 1965.

Subcommittee 2 continued to further develop refinements initiated by the simplification subgroup and to study changes suggested by consumer interests. This work culminated in Subcommittee acceptance of a 1970 proposal incorporating, in addition to numerous editorial changes, revisions to the requirements on angularity of bearing face and countersink diameters for the various hex nuts and heavy hex nuts, and inclusion of an appendix covering the gaging of slots in slotted nuts.

The proposed revision, after approval by letter ballot of the B18 Committee in March 1970, was subsequently approved by the sponsors and submitted to the American National Standards Institute for designation as an American National Standard. This was granted on January 18, 1972.

A proposed revision of this Standard agreed upon by Subcommittee 2 incorporated a provision to enable consumers to specify heavy hex nuts and heavy hex jam nuts with close bearing face angularity, when required; clarified intent with regard to width across flats on nuts produced from bar stock; deleted coverage for hex castle nuts from the appendices; and included numerous editorial refinements. This proposal was formally approved by letter ballot of the subcommittee and the B18 Committee. Following its acceptance by the sponsor organizations the revision was referred to the American National Standards Institute and granted approval as an American National Standard on February 27, 1987.

In March 2009 the B18.2 Subcommittee undertook a revision of this Standard. The format has been updated to meet the requirements of ASME B18.12.1. Regular pattern machine screw nuts have been moved from ASME B18.6.3, and the small pattern machine screw nuts have been added to this Standard. The hex flange nut that was previously referred to as IFI-145 has been added. Coupling nuts have been added. Many of the sizes came from the IFI-128 and others were based on what has been used for many years by industry. This proposal was formally approved by letter ballot of the subcommittee and the B18 Committee. Following its acceptance by the sponsor organizations, the revision was referred to the American National Standards Institute and granted approval as an American National Standard on August 24, 2010.

In September 2014 the B18.2 Subcommittee agreed to revise this Standard. Updates to the standard include correcting and expanding tabulated dimensions of small pattern hex machine screw nuts, revising washer face diameter tolerancing to be consistent with cap screws, a revised procedure for thread acceptance gaging of jam nuts, and a nonmandatory appendix with a procedure for measuring bearing surface runout. This revision was approved as an American National Standard on August 12, 2015.

ASME B18 COMMITTEE

Standardization of Bolts, Nuts, Rivets, Screws, Washers, and Similar Fasteners

(The following is the roster of the Committee at the time of approval of this Standard.)

STANDARDS COMMITTEE OFFICERS

J. Greenslade, *Chair*
D. S. George, *Vice Chair*
R. D. Strong, *Vice Chair*
C. J. Gomez, *Secretary*

STANDARDS COMMITTEE PERSONNEL

T. Anderson , Bay Bolt	W. H. King , Fastenal Co.
L. Borowski , Greenslade & Co., Inc.	D. Korneffel , <i>Contributing Member</i> , Cadenas PARTsolutions
V. Cartina , Nylok, LLC	J. F. McCarrick , Defense Supply Center Philadelphia
L. Claus , <i>Contributing Member</i> , NNI Training and Consulting, Inc.	J. Medcalf , Field Fastener
D. A. Clever , <i>Contributing Member</i> , Consultant	J. P. Nash , Caterpillar, Inc.
A. P. Cockman , Ford Motor Co.	F. J. Perry , John Deere
C. A. D. de la Garza , TSP, Inc.	M. D. Prasad , <i>Contributing Member</i> , Global M & F Solutions, Inc.
D. S. George , Ramco Specialties	D. F. Sharp , TurnaSure, LLC
C. J. Gomez , The American Society of Mechanical Engineers	Q. M. Smith III , Oregon DOT
J. Greenslade , Industrial Fasteners Institute	R. D. Strong , Doerken Corp.
J. J. Grey , <i>Contributing Member</i> , Fastener Consulting Services, Inc.	W. K. Wilcox , Consultant
A. Herskovitz , <i>Contributing Member</i> , Consultant	C. B. Williamson , Fastenal Co.
J. C. Jennings , <i>Contributing Member</i> , Naval Surface Warfare Center	C. J. Wilson , Consultant

SUBCOMMITTEE 16 — NUTS

J. Medcalf , <i>Chair</i> , Field Fastener	W. Guth , Electric Boat Corp.
D. S. George , <i>Vice Chair</i> , Ramco Specialties	J. C. Jennings , Naval Surface Warfare Center
T. Anderson , Bay Bolt	M. Kaindl , Aztech Locknut Co.
L. Borowski , Greenslade & Co., Inc.	W. H. King , Fastenal Co.
V. Cartina , Nylok, LLC	J. F. McCarrick , Defense Supply Center Philadelphia
E. Chen , Super Cheng Industrial Co., Ltd.	F. J. Perry , John Deere
A. P. Cockman , Ford Motor Co.	W. L. Sakowski , Account Managers, LLC
C. A. D. de la Garza , TSP, Inc.	R. M. Serabin , Freundlich Supply Co.
J. E. Dutton , Allegheny Castings	D. F. Sharp , TurnaSure, LLC
M. A. Elmi , Consultant	J. J. Stoczanskyj , Beacon Fasteners and Components, Inc.
M. C. Friel , Haydon Bolts, Inc.	R. D. Strong , Doerken Corp.
J. Greenslade , Industrial Fasteners Institute	L. White , Newport News Shipbuilding
J. J. Grey , Fastener Consulting Services, Inc.	W. K. Wilcox , Consultant
	C. J. Wilson , Consultant

CORRESPONDENCE WITH THE B18 COMMITTEE

General. ASME Standards are developed and maintained with the intent to represent the consensus of concerned interests. As such, users of this Standard may interact with the Committee by requesting interpretations, proposing revisions or a Case, and attending Committee meetings. Correspondence should be addressed to:

Secretary, B18 Standards Committee
The American Society of Mechanical Engineers
Two Park Avenue
New York, NY 10016-5990
<http://go.asme.org/Inquiry>

Proposing Revisions. Revisions are made periodically to the Standard to incorporate changes that appear necessary or desirable, as demonstrated by the experience gained from the application of the Standard. Approved revisions will be published periodically.

The Committee welcomes proposals for revisions to this Standard. Such proposals should be as specific as possible, citing the paragraph number(s), the proposed wording, and a detailed description of the reasons for the proposal, including any pertinent documentation.

Proposing a Case. Cases may be issued for the purpose of providing alternative rules when justified, to permit early implementation of an approved revision when the need is urgent, or to provide rules not covered by existing provisions. Cases are effective immediately upon ASME approval and shall be posted on the ASME Committee Web page.

Requests for Cases shall provide a Statement of Need and Background Information. The request should identify the Standard and the paragraph, figure, or table number(s), and be written as a Question and Reply in the same format as existing Cases. Requests for Cases should also indicate the applicable edition(s) of the Standard to which the proposed Case applies.

Interpretations. Upon request, the B18 Standards Committee will render an interpretation of any requirement of the Standard. Interpretations can only be rendered in response to a written request sent to the Secretary of the B18 Standards Committee at go.asme.org/Inquiry.

The request for an interpretation should be clear and unambiguous. It is further recommended that the inquirer submit his/her request in the following format:

Subject: Cite the applicable paragraph number(s) and the topic of the inquiry.
Edition: Cite the applicable edition of the Standard for which the interpretation is being requested.
Question: Phrase the question as a request for an interpretation of a specific requirement suitable for general understanding and use, not as a request for an approval of a proprietary design or situation. The inquirer may also include any plans or drawings that are necessary to explain the question; however, they should not contain proprietary names or information.

Requests that are not in this format may be rewritten in the appropriate format by the Committee prior to being answered, which may inadvertently change the intent of the original request.

ASME procedures provide for reconsideration of any interpretation when or if additional information that might affect an interpretation is available. Further, persons aggrieved by an interpretation may appeal to the cognizant ASME Committee or Subcommittee. ASME does not "approve," "certify," "rate," or "endorse" any item, construction, proprietary device, or activity.

Attending Committee Meetings. The B18 Standards Committee regularly holds meetings and/or telephone conferences that are open to the public. Persons wishing to attend any meeting and/or telephone conference should contact the Secretary of the B18 Standards Committee. Future Committee meeting dates and locations can be found on the Committee Page at go.asme.org/B18committee.

Nuts for General Applications: Machine Screw Nuts, Hex, Square, Hex Flange, and Coupling Nuts (Inch Series)

1 INTRODUCTION

1.1 Scope

1.1.1 This Standard is intended to cover the complete general and dimensional data for the various types of inch series square and hex nuts, including machine screw nuts and coupling nuts, addressed by this Standard. Also included are appendices covering gaging of slots in slotted nuts, wrench openings for nuts, formulas on which dimensional data are based, and measurement of bearing surface runout. It should be understood that where questions arise concerning acceptance of product, the dimensions in the tables shall govern over recalculation by formula.

1.1.2 The inclusion of dimensional data in this Standard is not intended to imply that all of the products described herein are stock production sizes. Consumers are requested to consult with manufacturers concerning lists of stock production sizes.

1.2 Comparison to ISO Standards

There are no comparable ISO inch fastener standards.

1.3 Dimensions

Unless otherwise indicated, units of measurement are expressed in inches.

1.4 Options

Where options are allowed, they shall be selected at the manufacturer's discretion unless otherwise specified by the purchaser.

1.5 Terminology References

For definitions of terminology not specifically defined in this Standard, refer to ASME B18.12.

2 REFERENCES

Unless otherwise specified, the standards referenced shall be the latest edition at the time of order placement.

ASME B1.1, Unified Inch Screw Threads (UN and UNR Thread Form)

ASME B1.3, Screw Thread Gaging Systems for Acceptability: Inch and Metric Screw Threads (UN, UNR, UNJ, M, and MJ)

ASME B18.12, Glossary of Terms for Mechanical Fasteners

ASME B18.18, Quality Assurance for Fasteners

ASME B18.24, Part Identifying Number (PIN) Code System for B18 Fastener Products

ASME B107 Series, Standards for Hand Tools

Publisher: The American Society of Mechanical Engineers (ASME), Two Park Avenue, New York, NY 10016-5990 (www.asme.org)

ASTM A563, Standard Specification for Carbon and Alloy Steel Nuts

ASTM F467, Standard Specification for Nonferrous Nuts for General Use

ASTM F594, Standard Specification for Stainless Steel Nuts

ASTM F1941, Specification for Electrodeposited Coatings on Threaded Fasteners [Unified Inch Screw Threads (UN/UNR)]

Publisher: American Society for Testing and Materials (ASTM International), 100 Barr Harbor Drive, P.O. Box C700, West Conshohocken, PA 19428-2959 (www.astm.org)

SAE J995, Mechanical and Material Requirements for Steel Nuts

Publisher: SAE International, 400 Commonwealth Drive, Warrendale, PA 15096 (www.sae.org)

3 GENERAL DATA

3.1 Width Across Flats

The width across flats of nut shall be the overall distance measured, perpendicular to the axis of nut, between two opposite sides of the nut in accordance with the notes on respective dimensional tables.

Maximum width across flats shall not be exceeded, except as stated below. No transverse section through the nut between 25% and 75% of the actual nut thickness as measured from the bearing surface shall be less than the minimum width across flats.

NOTE: Nonferrous milled-from-bar hex nuts: The minimum across flats dimensions of nonferrous milled-from-bar hex nuts shall not be less than the values tabulated in Tables 1-1 through 13. The maximum across flats size may be greater than the tabulated values in Tables 1-1 through 13, but shall not be equal to or

greater than the minimum wrench opening shown in Table B-1, Nonmandatory Appendix B.

3.2 Corner Fill

A rounding or lack of fill at junction of hex corners with chamfer shall be permissible, provided the width across corners is within specified limits at and beyond a distance equal to 17.5% of the basic thread diameter from the chamfered face.

3.3 Tops of Nuts and Chamfers

Tops of nuts shall be flat and chamfered. Unless otherwise specified by the purchaser or in this Standard, nuts in sizes $\frac{3}{8}$ in. nominal size and smaller shall be double-chamfered. Larger size nuts shall be double-chamfered or have washer-faced bearing surface and chamfered top.

3.3.1 Single-Chamfered Nuts and Washer-Faced Nuts. Diameter of the chamfer circle shall be equal to the maximum width across flats within a tolerance of -15% . The length of chamfer at hex corners shall be from 5% to 15% of the basic thread diameter. The surface of the chamfer may be slightly convex or rounded.

3.3.2 Double-Chamfered Nuts. Diameter of the chamfer circle shall be equal to the maximum width across flats with a -10% tolerance.

3.4 Countersink

Unless otherwise specified in this Standard, tapped holes shall be countersunk on the bearing faces. The maximum countersink diameter shall be the thread basic (nominal) major diameter plus 0.030 in. for $\frac{3}{8}$ in. nominal size nuts and smaller, and 1.08 times the basic major diameter for nuts larger than $\frac{3}{8}$ in. No part of the threaded portion shall project beyond the bearing surface.

3.5 Nut Thickness

The nut thickness shall be the overall distance, measured parallel to the axis of nut, from the top of the nut to the bearing surface and shall include the thickness of the washer face where provided.

3.6 Washer Face Diameter

Unless otherwise specified, the outside diameter of washer face shall be equal to the maximum width across flats with a -10% tolerance.

3.7 Slots

When specified in the respective dimensional table, slots shall be normal to nut flats. Contour of bottom of slots shall be at manufacturer's option. Requirements for gaging slots are specified in Mandatory Appendix I.

3.8 True Position of Tapped Hole

3.8.1 Hex Nuts. The axis of tapped hole in hex nuts shall be located at true position with respect to the axis

of nut body within a tolerance zone having a diameter equivalent to 4% of the maximum width across flats for $1\frac{1}{2}$ in. nominal size nuts or smaller and 6% of the maximum width across flats for nuts larger than $1\frac{1}{2}$ in., regardless of feature size.

3.8.2 Square Nuts. The axis of tapped hole in square nuts shall be located at true position with respect to the axis of nut body within a tolerance zone having a diameter equivalent to 10% of the maximum width across flats, regardless of feature size.

3.9 Bearing Surface Perpendicularity

Bearing surface shall be flat and perpendicular to the axis of the threaded hole within the specified full indicator measurement (FIM) limit indicated in the tables. See Nonmandatory Appendix C for measurement procedure.

3.10 Threads

3.10.1 Thread Standard. Threads shall meet the requirements of ASME B1.1.

3.10.2 Thread Class. Unless otherwise specified, threads shall be Unified Standard, Class 2B.

3.10.3 Thread Series. Thread series on nuts may be coarse (UNC), fine (UNF), or 8 thread series (8UN).

3.10.4 Thread Gaging. Unless otherwise specified by the purchaser, gaging for screw thread dimensional acceptability shall be in accordance with Gaging System 21 as specified in ASME B1.3, Screw Thread Gaging Systems for Acceptability.

3.10.4.1 Thread Gaging of Jam Nuts. Due to the three turn allowance and limited number of threads in jam nuts, NOT GO thread plug gages are not a reliable method for thread acceptance. Unless otherwise specified by the purchaser, jam nut thread acceptability shall be based on acceptance of the GO thread plug gage and nonacceptance of the NOT GO cylindrical plug gage to inspect minor diameter.

3.11 Material

Unless otherwise specified by the purchaser or elsewhere in this Standard, chemical and mechanical properties of steel nuts shall conform to Grade A of ASTM A563, Carbon and Alloy Steel Nuts or Grade 2 (square nuts only) of SAE J995. Nuts of other materials such as corrosion resistant (stainless) steel, brass, bronze, and aluminum alloys shall have properties as agreed upon between the manufacturer and purchaser. Refer to ASTM F594 for information on corrosion resistant alloy steel requirements and ASTM F467 for information on nonferrous materials.

3.12 Finish

Unless otherwise specified, nuts shall be supplied with a natural (as-processed) finish, unplated or

uncoated. If electroplated finishes are required, reference ASTM F1941. Other finishes may be specified as indicated in the applicable mechanical and performance standards.

3.13 Designation

3.13.1 Nuts shall be designated by the following data in the sequence shown: product name; dimensional standard, nominal size (fraction or decimal); threads per inch; basic width across flats (when applicable); mechanical and performance standard, and grade protective finish (including specification and thickness), if required.

EXAMPLES:

- (1) Square Nut, ASME B18.2.2, $\frac{1}{2}$ -13, ASTM A563 Grade A, Zinc Plated per ASTM F1941 Fe/Zn 3A
- (2) Hex Nut, ASME B18.2.2, $\frac{3}{4}$ -16, SAE J995 Grade 5, Steel

- (3) Hex Thick Slotted Nut, ASME B18.2.2, 1.000-8, ASTM F594 (Alloy Group 1) Corrosion Resistant Steel
- (4) Small Pattern Hex Machine Screw Nut, ASME B18.2.2, #10-32, $\frac{5}{16}$ Across Flats, Steel, Plain

3.13.2 For part identification numbers (PIN), refer to ASME B18.24.

3.14 Grade and Manufacturer's Identification Marking

Grade and manufacturer's markings shall be applied as required by the applicable mechanical and performance standard except that markings are not required for the machine screw nuts per Tables 1-1 and 1-2.

3.15 Inspection and Quality Assurance

Unless otherwise specified, product quality shall be determined according to ASME B18.18.

Table 1-1 Dimensions of Square and Hex Machine Screw Nuts

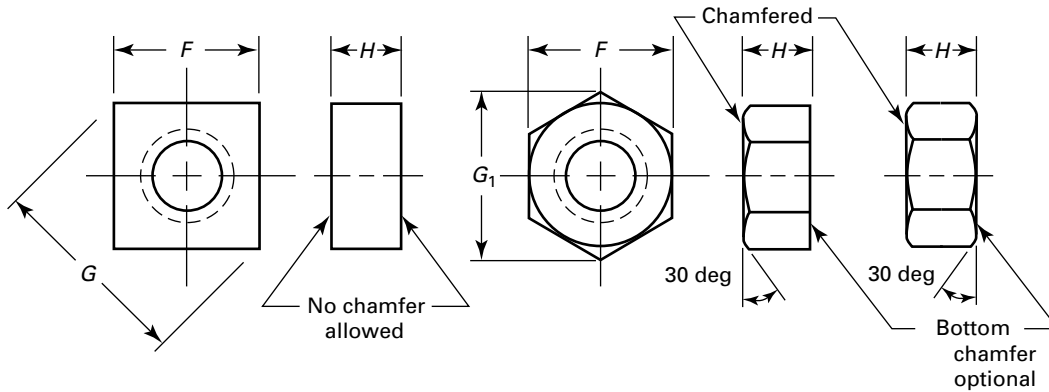

Nominal Size	Basic Major Diameter of Thread	Width Across Flats, <i>F</i>			Width Across Corners				Thickness, <i>H</i>		Bearing Surface Runout to Thread Axis, FIM
		Basic	Min.	Max.	Square, <i>G</i>		Hex, <i>G</i> ₁		Min.	Max.	
					Min.	Max.	Min.	Max.			
0	0.060	⁵ / ₃₂	0.150	0.156	0.206	0.221	0.171	0.180	0.043	0.050	0.005
1	0.073	⁵ / ₃₂	0.150	0.156	0.206	0.221	0.171	0.180	0.043	0.050	0.005
2	0.086	³ / ₁₆	0.180	0.188	0.247	0.265	0.205	0.217	0.057	0.066	0.006
3	0.099	³ / ₁₆	0.180	0.188	0.247	0.265	0.205	0.217	0.057	0.066	0.006
4	0.112	¹ / ₄	0.241	0.250	0.331	0.354	0.275	0.289	0.087	0.098	0.009
5	0.125	⁵ / ₁₆	0.302	0.312	0.415	0.442	0.344	0.361	0.102	0.114	0.011
6	0.138	⁵ / ₁₆	0.302	0.312	0.415	0.442	0.344	0.361	0.102	0.114	0.011
8	0.164	¹¹ / ₃₂	0.332	0.344	0.456	0.486	0.378	0.397	0.117	0.130	0.012
10	0.190	³ / ₈	0.362	0.375	0.497	0.530	0.413	0.433	0.117	0.130	0.013
12	0.216	⁷ / ₁₆	0.423	0.438	0.581	0.619	0.482	0.505	0.148	0.161	0.015
¹ / ₄	0.250	⁷ / ₁₆	0.423	0.438	0.581	0.619	0.482	0.505	0.178	0.193	0.015
⁵ / ₁₆	0.312	⁹ / ₁₆	0.545	0.562	0.748	0.795	0.621	0.650	0.208	0.225	0.020
³ / ₈	0.375	⁵ / ₈	0.607	0.625	0.833	0.884	0.692	0.722	0.239	0.257	0.021

GENERAL NOTES:

- (a) For additional requirements refer to section 3, General Data.
- (b) As shown in the figure, no countersink is required.
- (c) *Material.* Unless otherwise specified, machine screw nuts shall be made of carbon steel.
- (d) *Mechanical Property Requirements.* Unless the purchaser specifies otherwise in the inquiry and purchase documents, machine screw nuts have no mechanical requirements.

Table 1-2 Dimensions of Small Pattern Hex Machine Screw Nuts

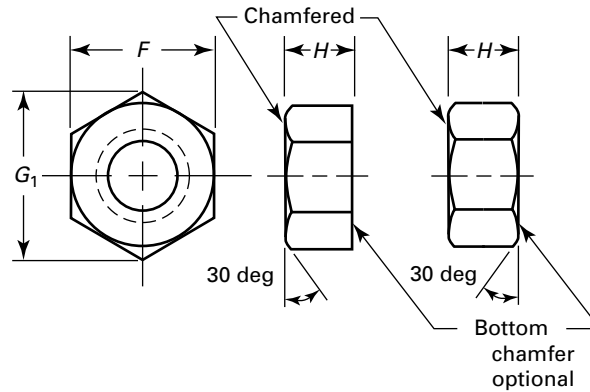

Nominal Size	Basic Major Diameter of Thread	Width Across Flats, F [Note (1)]			Width Across Corners, Hex, G_1		Thickness, H		Bearing Surface Runout to Thread Axis, FIM
		Basic	Min.	Max.	Min.	Max.	Min.	Max.	
0	0.060	$\frac{1}{8}$	0.121	0.125	0.134	0.140	0.043	0.050	0.005
1	0.073	$\frac{1}{8}$	0.121	0.125	0.134	0.140	0.043	0.050	0.005
2	0.086	$\frac{5}{32}$	0.150	0.156	0.171	0.180	0.057	0.066	0.006
3	0.099	$\frac{5}{32}$	0.150	0.156	0.171	0.180	0.057	0.066	0.006
4	0.112	$\frac{3}{16}$	0.180	0.188	0.205	0.217	0.057	0.066	0.009
5	0.125	$\frac{1}{4}$	0.241	0.250	0.275	0.289	0.087	0.098	0.011
6	0.138	$\frac{1}{4}$	0.241	0.250	0.275	0.289	0.087	0.098	0.011
8	0.164	$\frac{1}{4}$	0.241	0.250	0.275	0.289	0.087	0.098	0.012
8	0.164	$\frac{5}{16}$	0.302	0.312	0.344	0.361	0.102	0.114	0.012
10	0.190	$\frac{1}{4}$	0.241	0.250	0.275	0.289	0.087	0.098	0.013
10	0.190	$\frac{5}{16}$	0.302	0.312	0.344	0.361	0.102	0.114	0.013
10	0.190	$\frac{11}{32}$	0.332	0.344	0.378	0.397	0.117	0.130	0.013

GENERAL NOTES:

- (a) For additional requirements refer to section 3, General Data.
- (b) As shown in the figure, no countersink is required.
- (c) *Material.* Unless otherwise specified, machine screw nuts shall be made of carbon steel.
- (d) *Mechanical Property Requirements.* Unless the purchaser specifies otherwise in the inquiry and purchase documents, machine screw nuts have no mechanical requirements.

NOTE:

- (1) The purchaser shall specify the desired basic width across flats for those sizes with multiple options listed. Refer to para. 3.13.

Table 2 Dimensions of Square Nuts

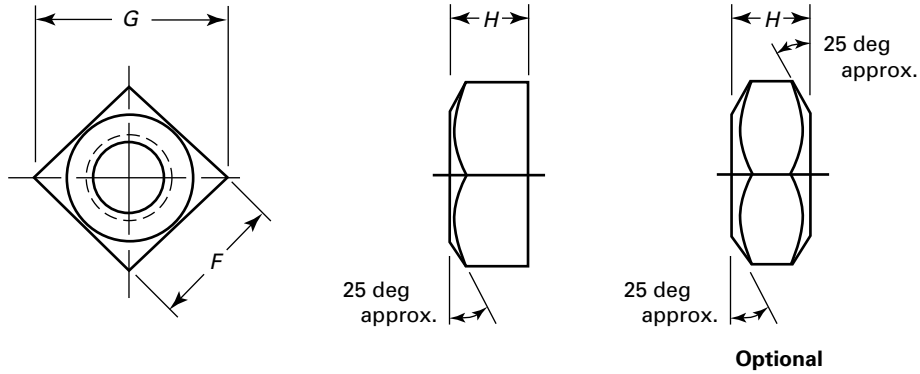

Nominal Size	Basic Major Diameter of Thread	Width Across Flats, <i>F</i> [Note (1)]			Width Across Corners, <i>G</i>		Thickness, <i>H</i>			Bearing Surface Runout to Thread Axis, FIM
		Basic	Min.	Max.	Min.	Max.	Basic	Min.	Max.	
1/4	0.2500	7/16	0.425	0.438	0.554	0.619	7/32	0.203	0.235	0.011
5/16	0.3125	9/16	0.547	0.562	0.721	0.795	17/64	0.249	0.283	0.015
3/8	0.3750	5/8	0.606	0.625	0.802	0.884	21/64	0.310	0.346	0.016
7/16	0.4375	3/4	0.728	0.750	0.970	1.061	3/8	0.356	0.394	0.019
1/2	0.5000	13/16	0.788	0.812	1.052	1.149	7/16	0.418	0.458	0.022
5/8	0.6250	1	0.969	1.000	1.300	1.414	35/64	0.525	0.569	0.026
3/4	0.7500	1 1/8	1.088	1.125	1.464	1.591	21/32	0.632	0.680	0.029
7/8	0.8750	1 5/16	1.269	1.312	1.712	1.856	49/64	0.740	0.792	0.034
1	1.0000	1 1/2	1.450	1.500	1.961	2.121	7/8	0.847	0.903	0.039
1 1/8	1.1250	1 11/16	1.631	1.688	2.209	2.386	1	0.970	1.030	0.029
1 1/4	1.2500	1 7/8	1.812	1.875	2.458	2.652	1 3/32	1.062	1.126	0.032
1 3/8	1.3750	2 1/16	1.994	2.062	2.708	2.917	1 13/64	1.169	1.237	0.035
1 1/2	1.5000	2 1/4	2.175	2.250	2.956	3.182	1 5/16	1.276	1.348	0.039

GENERAL NOTES:

- (a) For additional requirements, refer to section 3, General Data.
- (b) As shown in the figure, no countersink is required.

NOTE:

- (1) See para. 3.1.

Table 3 Dimensions of Hex Flat Nuts and Hex Flat Jam Nuts

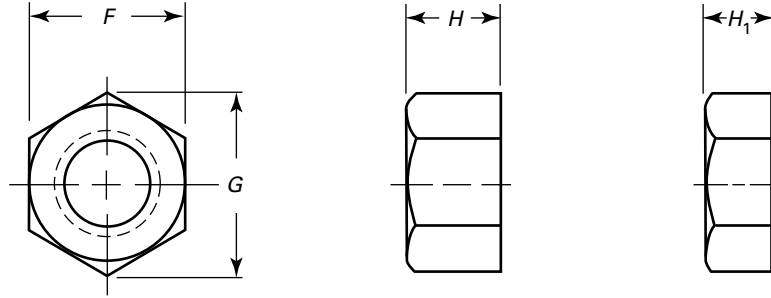

Nominal Size	Basic Major Diameter of Thread	Width Across Flats, <i>F</i> [Note (1)]			Width Across Corners, <i>G</i> [Note (2)]		Thickness Hex Flat Nuts, <i>H</i>			Thickness Hex Flat Jam Nuts, <i>H</i> ₁			Bearing Surface Runout to Thread Axis, FIM
		Basic	Min.	Max.	Min.	Max.	Basic	Min.	Max.	Basic	Min.	Max.	
1 ¹ / ₈	1.1250	1 ¹¹ / ₁₆	1.631	1.688	1.859	1.949	1	0.970	1.030	5/8	0.595	0.655	0.029
1 ¹ / ₄	1.2500	1 ⁷ / ₈	1.812	1.875	2.066	2.165	1 ³ / ₃₂	1.062	1.126	3/4	0.718	0.782	0.032
1 ³ / ₈	1.3750	2 ¹ / ₁₆	1.994	2.062	2.273	2.382	1 ¹³ / ₆₄	1.169	1.237	13/16	0.778	0.846	0.035
1 ¹ / ₂	1.5000	2 ¹ / ₄	2.175	2.250	2.480	2.598	1 ⁵ / ₁₆	1.276	1.348	7/8	0.839	0.911	0.039

GENERAL NOTES:

- (a) For additional requirements, refer to section 3, General Data.
- (b) As shown in the figure, no countersink is required.

NOTES:

- (1) See para. 3.1.
- (2) See para. 3.2.

Table 4 Dimensions of Hex Nuts and Hex Jam Nuts

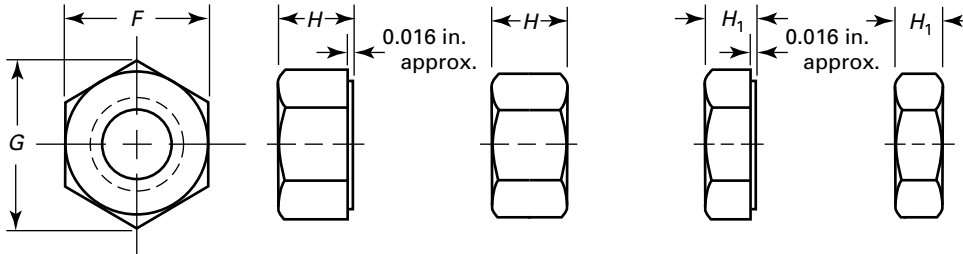

Nominal Size	Basic Major Diameter of Thread	Width Across Flats, <i>F</i>		Width Across Corners, <i>G</i>		Thickness Hex Nuts, <i>H</i>		Thickness Jam Nuts, <i>H</i> ₁		Maximum Runout of Bearing Surface to Thread Axis, FIM		
		Min.	Max.	Min.	Max.	Min.	Max.	Min.	Max.	Hex Nuts		Hex Jam Nuts
										Specified Proof Load		
										Up to 150,000 psi	150,000 psi and Greater	
1/4	0.2500	0.428	0.438	0.488	0.505	0.212	0.226	0.150	0.163	0.015	0.010	0.015
5/16	0.3125	0.489	0.500	0.557	0.577	0.258	0.273	0.180	0.195	0.016	0.011	0.016
3/8	0.3750	0.551	0.563	0.628	0.650	0.320	0.337	0.210	0.227	0.017	0.012	0.017
7/16	0.4375	0.675	0.688	0.768	0.794	0.365	0.385	0.240	0.260	0.018	0.013	0.018
1/2	0.5000	0.736	0.750	0.840	0.866	0.427	0.448	0.302	0.323	0.019	0.014	0.019
9/16	0.5625	0.861	0.875	0.982	1.010	0.473	0.496	0.301	0.324	0.020	0.015	0.020
5/8	0.6250	0.922	0.938	1.051	1.083	0.535	0.559	0.363	0.387	0.021	0.016	0.021
3/4	0.7500	1.088	1.125	1.240	1.299	0.617	0.665	0.398	0.446	0.023	0.018	0.023
7/8	0.8750	1.269	1.312	1.447	1.516	0.724	0.776	0.458	0.510	0.025	0.020	0.025
1	1.0000	1.450	1.500	1.653	1.732	0.831	0.887	0.519	0.575	0.027	0.022	0.027
1 1/8	1.1250	1.631	1.688	1.859	1.949	0.939	0.999	0.579	0.639	0.030	0.025	0.030
1 1/4	1.2500	1.812	1.875	2.066	2.165	1.030	1.094	0.687	0.751	0.033	0.028	0.033
1 3/8	1.3750	1.994	2.062	2.273	2.382	1.138	1.206	0.747	0.815	0.036	0.031	0.036
1 1/2	1.5000	2.175	2.250	2.480	2.598	1.245	1.317	0.808	0.880	0.039	0.034	0.039
1 5/8	1.6250	2.350	2.430	2.679	2.805	1.364	1.416	0.868	0.944	0.044	0.038	0.044
1 3/4	1.7500	2.538	2.625	2.893	3.031	1.460	1.540	0.929	1.009	0.048	0.041	0.048
1 7/8	1.8750	2.722	2.813	3.103	3.247	1.567	1.651	0.989	1.073	0.051	0.044	0.051
2	2.0000	2.900	3.000	3.306	3.464	1.675	1.763	1.050	1.138	0.055	0.047	0.055
2 1/4	2.2500	3.263	3.375	3.719	3.897	1.890	1.986	1.155	1.267	0.061	0.052	0.061
2 1/2	2.5000	3.625	3.750	4.133	4.330	2.105	2.209	1.401	1.427	0.068	0.058	0.068
2 3/4	2.7500	3.988	4.125	4.546	4.763	2.319	2.431	1.522	1.556	0.074	0.064	0.074
3	3.0000	4.350	4.500	4.959	5.196	2.534	2.654	1.643	1.685	0.081	0.070	0.081
3 1/4	3.2500	4.713	4.875	5.373	5.629	2.749	2.877	1.748	1.814	0.087	0.075	0.087
3 1/2	3.5000	5.075	5.250	5.786	6.062	2.964	3.100	1.870	1.943	0.094	0.081	0.094
3 3/4	3.7500	5.438	5.625	6.199	6.495	3.178	3.322	1.990	2.072	0.100	0.087	0.100
4	4.0000	5.800	6.000	6.612	6.928	3.393	3.545	2.112	2.201	0.107	0.093	0.107

GENERAL NOTE: For additional requirements, refer to section 3, General Data.

Table 5 Dimensions of Hex Slotted Nuts

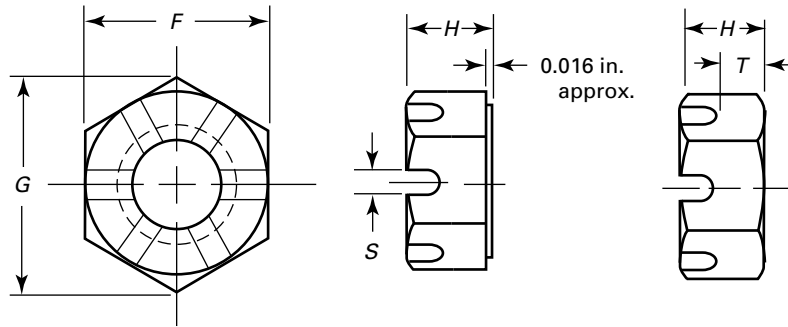

Nominal Size	Basic Major Diameter of Thread	Width Across Flats, F [Note (1)]			Width Across Corners, G [Note (2)]		Thickness, H			Unslotted Thickness, T [Note (3)]		Width of Slot, S [Note (3)]		Maximum Runout of Bearing Surface to Thread Axis, FIM [Note (4)]
		Basic	Min.	Max.	Min.	Max.	Basic	Min.	Max.	Min.	Max.	Min.	Max.	
$\frac{1}{4}$	0.2500	$\frac{7}{16}$	0.428	0.438	0.488	0.505	$\frac{7}{32}$	0.212	0.226	0.12	0.14	0.07	0.10	0.015
$\frac{5}{16}$	0.3125	$\frac{1}{2}$	0.489	0.500	0.557	0.577	$\frac{17}{64}$	0.258	0.273	0.16	0.18	0.09	0.12	0.016
$\frac{3}{8}$	0.3750	$\frac{9}{16}$	0.551	0.562	0.628	0.650	$\frac{21}{64}$	0.320	0.337	0.19	0.21	0.12	0.15	0.018
$\frac{7}{16}$	0.4375	$\frac{11}{16}$	0.675	0.688	0.768	0.794	$\frac{3}{8}$	0.365	0.385	0.21	0.23	0.12	0.15	0.018
$\frac{1}{2}$	0.5000	$\frac{3}{4}$	0.736	0.750	0.840	0.866	$\frac{7}{16}$	0.427	0.448	0.27	0.29	0.15	0.18	0.019
$\frac{9}{16}$	0.5625	$\frac{7}{8}$	0.861	0.875	0.982	1.010	$\frac{31}{64}$	0.473	0.496	0.29	0.31	0.15	0.18	0.020
$\frac{5}{8}$	0.6250	$\frac{15}{16}$	0.922	0.938	1.051	1.083	$\frac{35}{64}$	0.535	0.559	0.32	0.34	0.18	0.24	0.021
$\frac{3}{4}$	0.7500	$1\frac{1}{8}$	1.088	1.125	1.240	1.299	$\frac{41}{64}$	0.617	0.665	0.38	0.40	0.18	0.24	0.023
$\frac{7}{8}$	0.8750	$1\frac{5}{16}$	1.269	1.312	1.447	1.516	$\frac{3}{4}$	0.724	0.776	0.49	0.52	0.18	0.24	0.025
1	1.0000	$1\frac{1}{2}$	1.450	1.500	1.653	1.732	$\frac{55}{64}$	0.831	0.887	0.56	0.59	0.24	0.30	0.027
$1\frac{1}{8}$	1.1250	$1\frac{11}{16}$	1.631	1.688	1.859	1.949	$\frac{31}{32}$	0.939	0.999	0.61	0.64	0.24	0.33	0.030
$1\frac{1}{4}$	1.2500	$1\frac{7}{8}$	1.812	1.875	2.066	2.165	$1\frac{1}{16}$	1.030	1.094	0.67	0.70	0.31	0.40	0.033
$1\frac{3}{8}$	1.3750	$2\frac{1}{16}$	1.994	2.062	2.273	2.382	$1\frac{11}{64}$	1.138	1.206	0.78	0.82	0.31	0.40	0.036
$1\frac{1}{2}$	1.5000	$2\frac{1}{4}$	2.175	2.250	2.480	2.598	$1\frac{9}{32}$	1.245	1.317	0.82	0.86	0.37	0.46	0.039

GENERAL NOTE: For additional requirements, refer to section 3, General Data.

NOTES:

- (1) See para. 3.1.
- (2) See para. 3.2.
- (3) See para. 3.7.
- (4) See paras. 3.3 and 3.9.

Table 6 Dimensions of Hex Thick Nuts

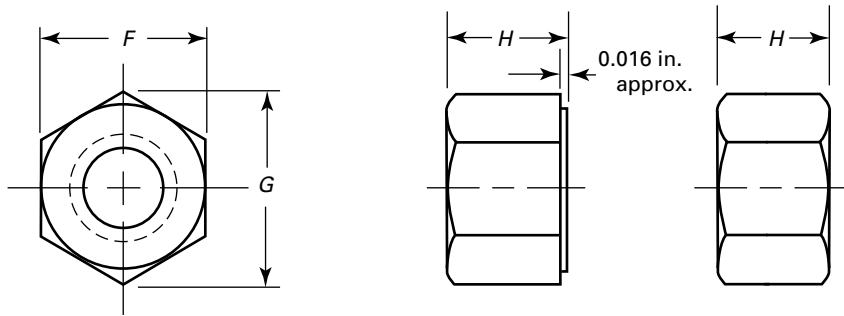

Nominal Size	Basic Major Diameter of Thread	Width Across Flats, <i>F</i> [Note (1)]			Width Across Corners, <i>G</i> [Note (2)]		Thickness, <i>H</i>			Maximum Runout of Bearing Surface to Thread Axis, <i>FIM</i> [Note (3)]	
		Basic	Min.	Max.	Min.	Max.	Basic	Min.	Max.	Specified Proof Load	
										Up to 150,000 psi	150,000 psi and Greater
1/4	0.2500	7/16	0.428	0.438	0.488	0.505	9/32	0.274	0.288	0.015	0.010
5/16	0.3125	1/2	0.489	0.500	0.557	0.577	21/64	0.320	0.336	0.016	0.011
3/8	0.3750	9/16	0.551	0.562	0.628	0.650	13/32	0.398	0.415	0.017	0.012
7/16	0.4375	11/16	0.675	0.688	0.768	0.794	29/64	0.444	0.463	0.018	0.013
1/2	0.5000	3/4	0.736	0.750	0.840	0.866	9/16	0.552	0.573	0.019	0.014
9/16	0.5625	7/8	0.861	0.875	0.892	1.010	39/64	0.598	0.621	0.020	0.015
5/8	0.6250	15/16	0.922	0.938	1.051	1.083	23/32	0.706	0.731	0.021	0.016
3/4	0.7500	1 1/8	1.088	1.125	1.240	1.299	13/16	0.798	0.827	0.023	0.018
7/8	0.8750	1 5/16	1.269	1.312	1.447	1.516	29/32	0.890	0.922	0.025	0.020
1	1.0000	1 1/2	1.450	1.500	1.653	1.732	1	0.982	1.018	0.027	0.022
1 1/8	1.1250	1 11/16	1.631	1.688	1.859	1.949	1 5/32	1.136	1.176	0.030	0.025
1 1/4	1.2500	1 7/8	1.812	1.875	2.066	2.165	1 1/4	1.228	1.272	0.033	0.028
1 3/8	1.3750	2 1/16	1.994	2.062	2.273	2.382	1 3/8	1.351	1.399	0.036	0.031
1 1/2	1.5000	2 1/4	2.175	2.250	2.480	2.598	1 1/2	1.474	1.526	0.039	0.034

GENERAL NOTE: For additional requirements, refer to section 3, General Data.

NOTES:

- (1) See para. 3.1.
- (2) See para. 3.2.
- (3) See paras. 3.3 and 3.9.

Table 7 Dimensions of Hex Thick Slotted Nuts

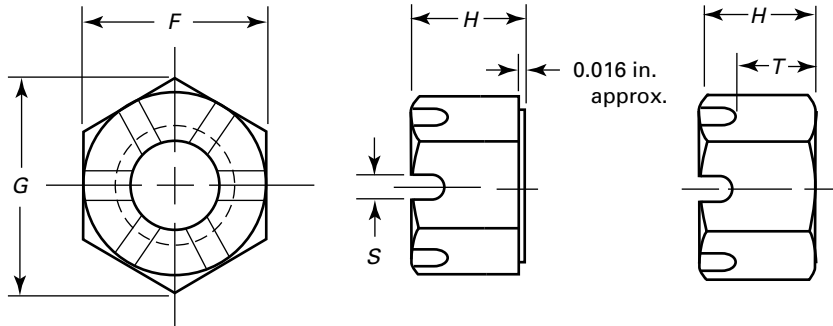

Nominal Size	Basic Major Diameter of Thread	Width Across Flats, <i>F</i> [Note (1)]			Width Across Corners, <i>G</i> [Note (2)]		Thickness, <i>H</i>			Unslotted Thickness, <i>T</i> [Note (3)]		Width of Slot, <i>S</i> [Note (3)]		Maximum Runout of Bearing Surface to Thread Axis, FIM [Note (4)]
		Basic	Min.	Max.	Min.	Max.	Basic	Min.	Max.	Min.	Max.	Min.	Max.	
1/4	0.2500	7/16	0.428	0.438	0.488	0.505	9/32	0.274	0.288	0.18	0.20	0.07	0.10	0.015
5/16	0.3125	1/2	0.489	0.500	0.557	0.577	21/64	0.320	0.336	0.22	0.24	0.09	0.12	0.016
3/8	0.3750	9/16	0.551	0.562	0.628	0.650	13/32	0.398	0.415	0.27	0.29	0.12	0.15	0.017
7/16	0.4375	11/16	0.675	0.688	0.768	0.794	29/64	0.444	0.463	0.29	0.31	0.12	0.15	0.018
1/2	0.5000	3/4	0.736	0.750	0.840	0.866	9/16	0.552	0.573	0.40	0.42	0.15	0.18	0.019
9/16	0.5625	7/8	0.861	0.875	0.982	1.010	39/64	0.598	0.621	0.41	0.43	0.15	0.18	0.020
5/8	0.6250	15/16	0.922	0.938	1.051	1.083	23/32	0.706	0.731	0.49	0.51	0.18	0.24	0.021
3/4	0.7500	1 1/8	1.088	1.125	1.240	1.299	13/16	0.798	0.827	0.55	0.57	0.18	0.24	0.023
7/8	0.8750	1 5/16	1.269	1.312	1.447	1.516	29/32	0.890	0.922	0.64	0.67	0.18	0.24	0.025
1	1.0000	1 1/2	1.450	1.500	1.653	1.732	1	0.982	1.018	0.70	0.73	0.24	0.30	0.027
1 1/8	1.1250	1 11/16	1.631	1.688	1.859	1.949	1 5/32	1.136	1.176	0.80	0.83	0.24	0.33	0.030
1 1/4	1.2500	1 7/8	1.812	1.875	2.066	2.165	1 1/4	1.228	1.272	0.86	0.89	0.31	0.40	0.033
1 3/8	1.3750	2 1/16	1.994	2.062	2.273	2.382	1 3/8	1.351	1.399	0.98	1.02	0.31	0.40	0.036
1 1/2	1.5000	2 1/4	2.175	2.250	2.480	2.598	1 1/2	1.474	1.526	1.04	1.08	0.37	0.46	0.039

GENERAL NOTE: For additional requirements, refer to section 3, General Data.

NOTES:

- (1) See para. 3.1.
- (2) See para. 3.2.
- (3) See para. 3.7.
- (4) See paras. 3.3 and 3.9.

Table 8 Dimensions of Heavy Square Nuts

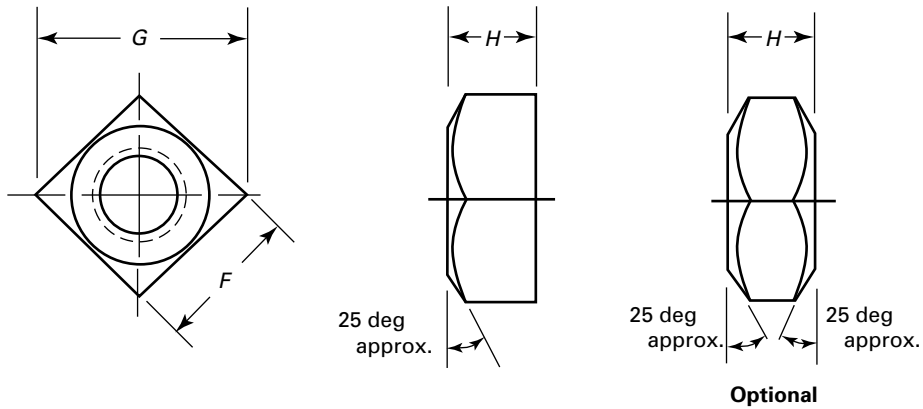

Nominal Size	Basic Major Diameter of Thread	Width Across Flats, F [Note (1)]			Width Across Corners, G		Thickness, H			Bearing Surface Runout to Thread Axis, FIM
		Basic	Min.	Max.	Min.	Max.	Basic	Min.	Max.	
1/4	0.2500	1/2	0.488	0.500	0.640	0.707	1/4	0.218	0.266	0.026
5/16	0.3125	9/16	0.546	0.562	0.720	0.795	5/16	0.280	0.330	0.030
3/8	0.3750	11/16	0.669	0.688	0.889	0.973	3/8	0.341	0.393	0.036
7/16	0.4375	3/4	0.728	0.750	0.970	1.060	7/16	0.403	0.456	0.039
1/2	0.5000	7/8	0.850	0.875	1.137	1.237	1/2	0.464	0.520	0.046
5/8	0.6250	1 1/16	1.031	1.062	1.386	1.503	5/8	0.587	0.647	0.056
3/4	0.7500	1 1/4	1.212	1.250	1.635	1.768	3/4	0.710	0.774	0.065
7/8	0.8750	1 7/16	1.394	1.438	1.884	2.033	7/8	0.833	0.901	0.075
1	1.0000	1 5/8	1.575	1.625	2.132	2.298	1	0.956	1.028	0.082
1 1/8	1.1250	1 13/16	1.756	1.812	2.381	2.563	1 1/8	1.079	1.155	0.063
1 1/4	1.2500	2	1.938	2.000	2.631	2.828	1 1/4	1.187	1.282	0.070
1 3/8	1.3750	2 3/16	2.119	2.188	2.879	3.094	1 3/8	1.310	1.409	0.076
1 1/2	1.5000	2 3/8	2.300	2.375	3.128	3.359	1 1/2	1.433	1.536	0.082

GENERAL NOTES:

- (a) For additional requirements, refer to section 3, General Data.
- (b) As shown in the figure, no countersink is required.

NOTE:

- (1) See para. 3.1.

Table 9 Dimensions of Heavy Hex Flat Nuts and Heavy Hex Flat Jam Nuts

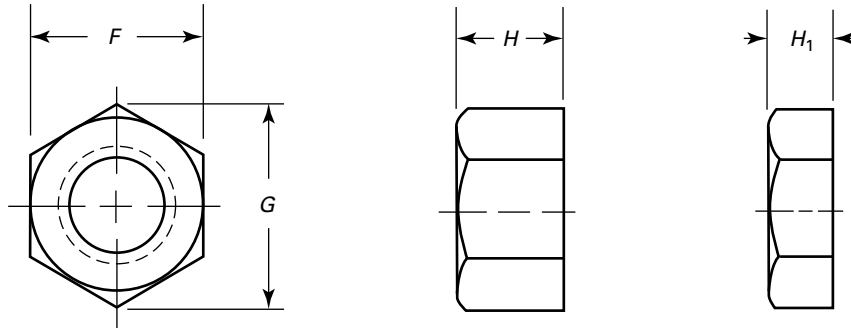

Nominal Size	Basic Major Diameter of Thread	Width Across Flats, <i>F</i> [Note (1)]			Width Across Corners, <i>G</i> [Note (2)]		Thickness Heavy Hex Flat Nuts, <i>H</i>			Thickness Heavy Hex Flat Jam Nuts, <i>H</i> ₁			Bearing Surface Runout to Thread Axis, FIM
		Basic	Min.	Max.	Min.	Max.	Basic	Min.	Max.	Basic	Min.	Max.	
1 ¹ / ₈	1.1250	1 ¹³ / ₁₆	1.756	1.812	2.002	2.093	1 ¹ / ₈	1.079	1.155	5 ⁵ / ₈	0.579	0.655	0.032
1 ¹ / ₄	1.2500	2	1.938	2.000	2.209	2.309	1 ¹ / ₄	1.187	1.282	3 ³ / ₄	0.687	0.782	0.034
1 ³ / ₈	1.3750	2 ³ / ₁₆	2.119	2.188	2.416	2.526	1 ³ / ₈	1.310	1.409	1 ¹³ / ₁₆	0.747	0.846	0.038
1 ¹ / ₂	1.5000	2 ³ / ₈	2.300	2.375	2.622	2.742	1 ¹ / ₂	1.433	1.536	7 ⁷ / ₈	0.808	0.911	0.041
1 ³ / ₄	1.7500	2 ³ / ₄	2.662	2.750	3.035	3.175	1 ³ / ₄	1.679	1.790	1	0.929	1.040	0.048
2	2.0000	3 ¹ / ₈	3.025	3.125	3.449	3.608	2	1.925	2.044	1 ¹ / ₈	1.050	1.169	0.054
2 ¹ / ₄	2.2500	3 ¹ / ₂	3.388	3.500	3.862	4.041	2 ¹ / ₄	2.155	2.298	1 ¹ / ₄	1.155	1.298	0.061
2 ¹ / ₂	2.5000	3 ⁷ / ₈	3.750	3.875	4.275	4.474	2 ¹ / ₂	2.401	2.552	1 ¹ / ₂	1.401	1.552	0.067
2 ³ / ₄	2.7500	4 ¹ / ₄	4.112	4.250	4.688	4.907	2 ³ / ₄	2.647	2.806	1 ⁵ / ₈	1.522	1.681	0.074
3	3.0000	4 ⁵ / ₈	4.475	4.625	5.102	5.340	3	2.893	3.060	1 ³ / ₄	1.643	1.810	0.080
3 ¹ / ₄	3.2500	5	4.838	5.000	5.515	5.774	3 ¹ / ₄	3.124	3.314	1 ⁷ / ₈	1.748	1.939	0.087
3 ¹ / ₂	3.5000	5 ³ / ₈	5.200	5.375	5.928	6.207	3 ¹ / ₂	3.370	3.568	2	1.870	2.068	0.093
3 ³ / ₄	3.7500	5 ⁷ / ₄	5.562	5.750	6.341	6.640	3 ³ / ₄	3.616	3.822	2 ¹ / ₈	1.990	2.197	0.100
4	4.0000	6 ¹ / ₈	5.925	6.125	6.755	7.073	4	3.862	4.076	2 ¹ / ₄	2.112	2.326	0.107

GENERAL NOTES:

- (a) For additional requirements, refer to section 3, General Data.
- (b) As shown in the figure, no countersink is required.

NOTES:

- (1) See para. 3.1.
- (2) See para. 3.2.

Table 10 Dimensions of Heavy Hex Nuts and Heavy Hex Jam Nuts

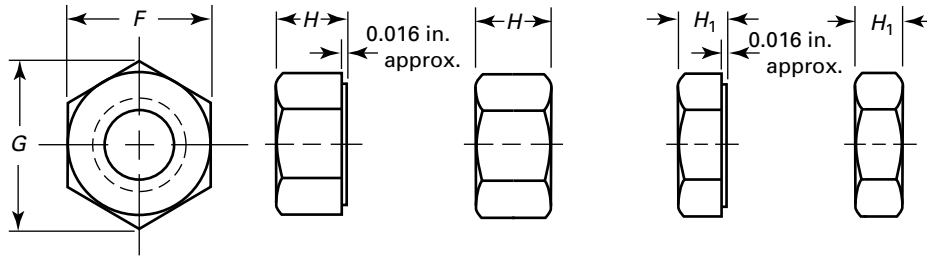

Nominal Size	Basic Major Diameter of Thread	Width Across Flats, <i>F</i> [Note (1)]					Width Across Corners, <i>G</i> [Note (2)]		Thickness Heavy Hex Nuts, <i>H</i>			Thickness Heavy Hex Jam Nuts, <i>H</i> ₁			Maximum Runout of Bearing Surface to Thread Axis, FIM [Note (3)]		
		Basic		Min.		Max.	Min.	Max.	Basic	Min.	Max.	Basic	Min.	Max.	Up to 150,000 psi	150,000 psi and Greater	All Strength Levels
		Basic	Min.	Max.	Min.	Max.	Basic	Min.	Max.	Basic	Min.	Max.	psi	psi and Greater			
1/4	0.2500	1/2	0.488	0.500	0.556	0.577	15/64	0.218	0.250	11/64	0.156	0.188	0.017	0.011	0.017		
5/16	0.3125	9/16	0.546	0.562	0.622	0.650	19/64	0.280	0.314	13/64	0.186	0.220	0.020	0.012	0.020		
3/8	0.3750	11/16	0.669	0.688	0.763	0.794	23/64	0.341	0.377	15/64	0.216	0.252	0.021	0.014	0.021		
7/16	0.4375	3/4	0.728	0.750	0.830	0.866	27/64	0.403	0.441	17/64	0.247	0.285	0.022	0.015	0.022		
1/2	0.5000	7/8	0.850	0.875	0.969	1.010	31/64	0.464	0.504	19/64	0.277	0.317	0.023	0.016	0.023		
9/16	0.5625	15/16	0.909	0.938	1.037	1.083	35/64	0.526	0.568	21/64	0.307	0.349	0.024	0.017	0.024		
5/8	0.6250	1 1/16	1.031	1.062	1.175	1.227	39/64	0.587	0.631	23/64	0.337	0.381	0.025	0.018	0.025		
3/4	0.7500	1 1/4	1.212	1.250	1.382	1.443	47/64	0.710	0.758	27/64	0.398	0.446	0.027	0.020	0.027		
7/8	0.8750	1 7/16	1.394	1.438	1.589	1.660	55/64	0.833	0.885	31/64	0.458	0.510	0.029	0.022	0.029		
1	1.0000	1 7/8	1.575	1.625	1.796	1.876	63/64	0.956	1.012	35/64	0.519	0.575	0.031	0.024	0.031		
1 1/8	1.1250	1 13/16	1.756	1.812	2.002	2.093	71/64	1.079	1.139	39/64	0.579	0.639	0.033	0.027	0.033		
1 1/4	1.2500	2	1.938	2.000	2.209	2.309	1 7/32	1.187	1.251	23/32	0.687	0.751	0.035	0.030	0.035		
1 3/8	1.3750	2 3/16	2.119	2.188	2.416	2.526	1 11/32	1.310	1.378	25/32	0.747	0.815	0.038	0.033	0.038		
1 1/2	1.5000	2 3/8	2.300	2.375	2.622	2.742	1 15/32	1.433	1.505	27/32	0.808	0.880	0.041	0.036	0.041		
1 5/8	1.6250	2 9/16	2.481	2.562	2.828	2.959	1 19/32	1.556	1.632	29/32	0.868	0.944	0.044	0.038	0.044		
1 3/4	1.7500	2 3/4	2.662	2.750	3.035	3.175	1 23/32	1.679	1.759	31/32	0.929	1.009	0.048	0.041	0.048		
1 7/8	1.8750	2 15/16	2.844	2.938	3.242	3.392	1 27/32	1.802	1.886	1 1/32	0.989	1.073	0.051	0.044	0.051		
2	2.0000	3 1/8	3.025	3.125	3.449	3.608	1 31/32	1.925	2.013	1 3/32	1.050	1.138	0.055	0.047	0.055		
2 1/4	2.2500	3 1/2	3.388	3.500	3.862	4.041	2 13/64	2.155	2.251	1 13/64	1.155	1.251	0.061	0.052	0.061		
2 1/2	2.5000	3 7/8	3.750	3.875	4.275	4.474	2 29/64	2.401	2.505	1 29/64	1.401	1.505	0.068	0.058	0.068		
2 3/4	2.7500	4 1/4	4.112	4.250	4.688	4.907	2 45/64	2.647	2.759	1 37/64	1.522	1.634	0.074	0.064	0.074		
3	3.0000	4 5/8	4.475	4.625	5.102	5.340	2 61/64	2.893	3.013	1 45/64	1.643	1.763	0.081	0.070	0.081		
3 1/4	3.2500	5	4.838	5.000	5.515	5.774	3 3/16	3.124	3.252	1 13/16	1.748	1.876	0.087	0.075	0.087		
3 1/2	3.5000	5 3/8	5.200	5.375	5.928	6.207	3 7/16	3.370	3.506	1 15/16	1.870	2.006	0.094	0.081	0.094		
3 3/4	3.7500	5 3/4	5.562	5.750	6.341	6.640	3 11/16	3.616	3.760	2 1/16	1.990	2.134	0.100	0.087	0.100		
4	4.0000	6 1/8	5.925	6.125	6.755	7.073	3 15/16	3.862	4.014	2 3/16	2.112	2.264	0.107	0.093	0.107		

GENERAL NOTES:

- (a) For additional requirements refer to section 3, General Data.
- (b) *Chamfers and Washer Faces.* Nuts in sizes 7/16 in. nominal size and smaller shall be double-chamfered. Larger size nuts shall be double-chamfered or have washer-faced bearing surface and chamfered top.
- (c) *Optional Bearing Surface Runout.* Where purchaser specifies close runout of bearing face style heavy hex or heavy hex jam nuts in nominal sizes 2 in. to 4 in., nuts shall be so processed as to have a maximum bearing face runout of 0.010 in. FIM.

NOTES:

- (1) See para. 3.1.
- (2) See para. 3.2.
- (3) See paras. 3.3 and 3.9.

Table 11 Dimensions of Heavy Hex Slotted Nuts

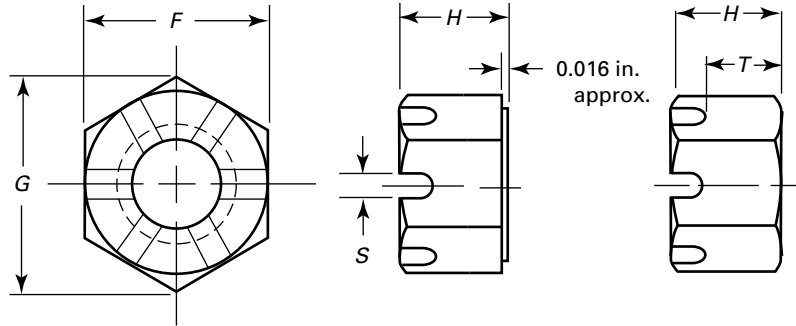

Nominal Size	Basic Major Diameter of Thread	Width Across Flats, F [Note (1)]			Width Across Corners, G [Note (2)]		Thickness, H			Unslotted Thickness, T [Note (3)]		Width of Slot, S [Note (3)]		Maximum Runout of Bearing Surface to Thread Axis, FIM [Note (4)]
		Basic	Min.	Max.	Min.	Max.	Basic	Min.	Max.	Min.	Max.	Min.	Max.	
1/4	0.2500	1/2	0.488	0.500	0.556	0.577	15/64	0.218	0.250	0.13	0.15	0.07	0.10	0.017
5/16	0.3125	9/16	0.546	0.562	0.622	0.650	19/64	0.280	0.314	0.19	0.21	0.09	0.12	0.020
3/8	0.3750	11/16	0.669	0.688	0.763	0.794	23/64	0.341	0.377	0.22	0.24	0.12	0.15	0.021
7/16	0.4375	3/4	0.728	0.750	0.830	0.866	27/64	0.403	0.441	0.26	0.28	0.12	0.15	0.022
1/2	0.5000	7/8	0.850	0.875	0.969	1.010	31/64	0.464	0.504	0.32	0.34	0.15	0.18	0.023
9/16	0.5625	15/16	0.909	0.938	1.037	1.083	35/64	0.526	0.568	0.35	0.37	0.15	0.18	0.024
5/8	0.6250	1 1/16	1.031	1.062	1.175	1.227	39/64	0.587	0.631	0.38	0.40	0.18	0.24	0.025
3/4	0.7500	1 1/4	1.212	1.250	1.382	1.443	47/64	0.710	0.758	0.47	0.49	0.18	0.24	0.027
7/8	0.8750	1 7/16	1.394	1.438	1.589	1.660	55/64	0.833	0.885	0.59	0.62	0.18	0.24	0.029
1	1.0000	1 3/8	1.575	1.625	1.796	1.876	63/64	0.956	1.012	0.69	0.72	0.24	0.30	0.031
1 1/8	1.1250	1 13/16	1.756	1.812	2.002	2.093	1 7/64	1.079	1.139	0.75	0.78	0.24	0.33	0.033
1 1/4	1.2500	2	1.938	2.000	2.209	2.309	1 1/32	1.187	1.251	0.83	0.86	0.31	0.40	0.035
1 3/8	1.3750	2 3/16	2.119	2.188	2.416	2.526	1 11/32	1.310	1.378	0.95	0.99	0.31	0.40	0.038
1 1/2	1.5000	2 3/8	2.300	2.375	2.622	2.742	1 15/32	1.433	1.505	1.01	1.05	0.37	0.46	0.041
1 3/4	1.7500	2 3/4	2.662	2.750	3.035	3.175	1 23/32	1.679	1.759	1.20	1.24	0.43	0.52	0.048
2	2.0000	3 3/8	3.025	3.125	3.449	3.608	1 31/32	1.925	2.013	1.38	1.43	0.43	0.52	0.055
2 1/4	2.2500	3 1/2	3.388	3.500	3.862	4.041	2 13/64	2.155	2.251	1.62	1.67	0.43	0.52	0.061
2 1/2	2.5000	3 7/8	3.750	3.875	4.275	4.474	2 29/64	2.401	2.505	1.74	1.79	0.55	0.64	0.068
2 3/4	2.7500	4 1/4	4.112	4.250	4.688	4.907	2 45/64	2.647	2.759	1.99	2.05	0.55	0.64	0.074
3	3.0000	4 5/8	4.475	4.625	5.102	5.340	2 61/64	2.893	3.013	2.17	2.23	0.62	0.71	0.081
3 1/4	3.2500	5	4.838	5.000	5.515	5.774	3 3/16	3.124	3.252	2.41	2.47	0.62	0.71	0.087
3 1/2	3.5000	5 3/8	5.200	5.375	5.928	6.207	3 7/16	3.370	3.506	2.65	2.72	0.62	0.71	0.094
3 3/4	3.7500	5 3/4	5.562	5.750	6.341	6.640	3 11/16	3.616	3.760	2.90	2.97	0.62	0.71	0.100
4	4.0000	6 1/8	5.925	6.125	6.755	7.073	3 15/16	3.862	4.014	3.15	3.22	0.62	0.71	0.107

GENERAL NOTES:

- (a) For additional requirements, refer to section 3, General Data.
- (b) *Chamfers and Washer Faces.* Nuts in sizes 7/16 in. nominal size and smaller shall be double-chamfered. Larger size nuts shall be double-chamfered or have washer-faced bearing surface and chamfered top.

NOTES:

- (1) See para. 3.1.
- (2) See para. 3.2.
- (3) See para. 3.7.
- (4) See paras. 3.3 and 3.9.

Table 12 Dimensions of Hex Flange Nuts and Large Hex Flange Nuts

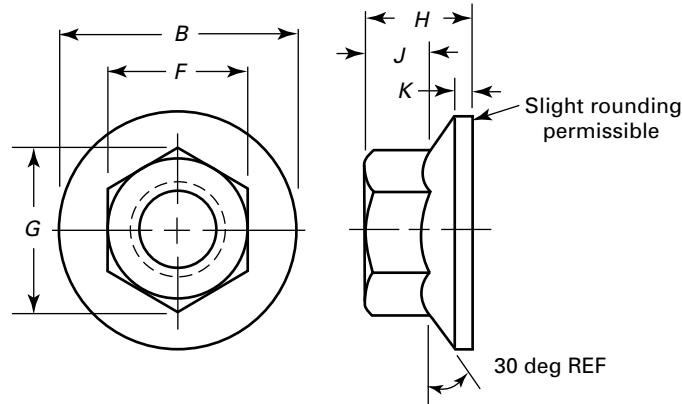

Nominal Size	Basic Major Diameter of Thread	Width Across Flats, F		Width Across Corners, G		Diameter of Flange, B		Nut Thickness, H		Minimum Wrenching Length, J	Minimum Flange Thickness, K	Maximum Runout of Bearing Surface to Thread Axis, FIM
		Min.	Max.	Min.	Max.	Min.	Max.	Min.	Max.			
Hex Flange Nuts												
No. 6	0.1380	0.302	0.312	0.342	0.361	0.406	0.422	0.156	0.171	0.10	0.02	0.014
8	0.1640	0.334	0.344	0.381	0.397	0.452	0.469	0.187	0.203	0.13	0.02	0.016
10	0.1900	0.365	0.375	0.416	0.433	0.480	0.500	0.203	0.219	0.13	0.03	0.017
12	0.2160	0.428	0.438	0.488	0.505	0.574	0.594	0.222	0.236	0.14	0.04	0.020
1/4	0.2500	0.428	0.438	0.488	0.505	0.574	0.594	0.222	0.236	0.14	0.04	0.020
5/16	0.3125	0.489	0.500	0.557	0.577	0.660	0.680	0.268	0.283	0.17	0.04	0.023
3/8	0.3750	0.551	0.562	0.628	0.650	0.728	0.750	0.330	0.347	0.23	0.04	0.025
7/16	0.4375	0.675	0.688	0.768	0.794	0.910	0.937	0.375	0.395	0.26	0.04	0.032
1/2	0.5000	0.736	0.750	0.840	0.866	1.000	1.031	0.437	0.458	0.31	0.05	0.035
9/16	0.5625	0.861	0.875	0.982	1.010	1.155	1.188	0.483	0.506	0.35	0.05	0.040
5/8	0.6250	0.922	0.938	1.051	1.083	1.248	1.281	0.545	0.569	0.40	0.05	0.044
3/4	0.7500	1.088	1.125	1.240	1.299	1.460	1.500	0.627	0.675	0.46	0.06	0.051
Large Hex Flange Nuts												
1/4	0.2500	0.428	0.438	0.488	0.505	0.700	0.728	0.281	0.312	0.15	0.04	0.024
5/16	0.3125	0.489	0.500	0.557	0.577	0.790	0.820	0.343	0.375	0.20	0.04	0.028
3/8	0.3750	0.551	0.562	0.628	0.650	0.885	0.915	0.390	0.406	0.24	0.04	0.031
7/16	0.4375	0.675	0.688	0.768	0.794	1.100	1.131	0.437	0.468	0.26	0.04	0.038
1/2	0.5000	0.736	0.750	0.840	0.866	1.175	1.205	0.485	0.515	0.29	0.06	0.041
9/16	0.5625	0.861	0.875	0.982	1.010	1.260	1.300	0.546	0.578	0.37	0.06	0.044
5/8	0.6250	0.922	0.938	1.051	1.083	1.280	1.360	0.600	0.640	0.42	0.06	0.045

GENERAL NOTES:

- (a) For additional requirements refer to section 3, General Data.
- (b) *Concentricity of Tapped Hole.* Axis of tapped hole shall be concentric with axis of nut body within a tolerance equal to 3% (6% FIM) of the maximum width across flats.

Table 13 Dimensions of Hex Coupling Nuts

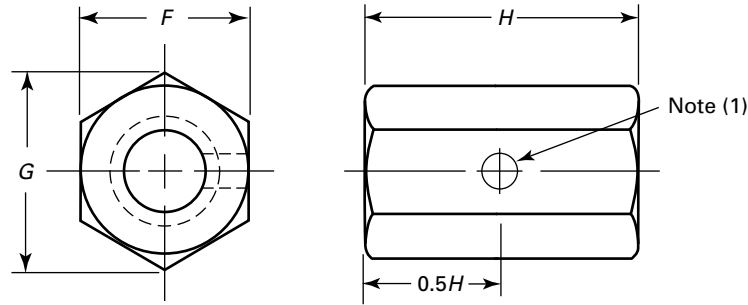

Nominal Size	Basic Major Diameter of Thread	Width Across Flats, F			Width Across Corners, G		Length, H		
		Basic	Min.	Max.	Min.	Max.	Basic	Min.	Max.
#6	0.138	5/16	0.302	0.312	0.344	0.361	1/2	0.470	0.510
#8	0.164	5/16	0.302	0.312	0.344	0.361	5/8	0.595	0.645
#10	0.190	5/16	0.302	0.312	0.344	0.361	3/4	0.711	0.760
1/4	0.250	7/16	0.428	0.438	0.488	0.505	1 3/4	1.690	1.760
5/16	0.312	1/2	0.489	0.500	0.557	0.577	1 3/4	1.690	1.760
3/8	0.375	9/16	0.551	0.562	0.628	0.650	1 3/4	1.690	1.760
7/16	0.437	5/8	0.607	0.625	0.692	0.722	1 3/4	1.690	1.760
1/2	0.500	11/16	0.663	0.688	0.756	0.794	1 3/4	1.690	1.760
9/16	0.562	13/16	0.782	0.813	0.891	0.939	2 1/8	2.067	2.135
5/8	0.625	13/16	0.782	0.813	0.891	0.939	2 1/8	2.067	2.135
3/4	0.750	1	0.963	1.000	1.097	1.155	2 1/4	2.190	2.260
7/8	0.875	1 1/4	1.212	1.250	1.382	1.443	2 1/2	2.440	2.510
1	1.000	1 3/8	1.325	1.375	1.511	1.588	2 3/4	2.690	2.760
1 1/8	1.125	1 1/2	1.450	1.500	1.653	1.732	3	2.940	3.010
1 1/4	0.125	1 5/8	1.575	1.625	1.825	1.876	3	2.940	3.010
1 1/2	1.500	2	1.950	2.000	2.275	2.309	3 1/2	3.440	3.510
1 5/8	1.625	2 9/16	2.481	2.562	2.828	2.959	4 7/8	4.830	4.910
1 3/4	1.750	2 3/4	2.662	2.750	3.035	3.175	5 1/4	5.210	5.290
1 7/8	1.875	2 15/16	2.844	2.938	3.242	3.392	5 5/8	5.580	5.670
2	2.000	3 1/8	3.025	3.125	3.448	3.608	6	5.950	6.040
2 1/4	2.250	3 1/2	3.388	3.500	3.862	4.041	6 3/4	6.700	6.800
2 1/2	2.500	3 7/8	3.750	3.875	4.275	4.474	7 1/2	7.440	7.550
2 3/4	2.750	4 1/4	4.112	4.250	4.688	4.907	8 1/4	8.190	8.310
3	3.000	4 5/8	4.475	4.625	5.101	5.340	9	8.940	9.060
3 1/4	3.250	5	4.838	5.000	5.515	5.773	9 3/4	9.680	9.810
3 1/2	3.500	5 3/8	5.200	5.375	5.928	6.206	10 1/2	10.430	10.570
3 3/4	3.750	5 3/4	5.562	5.750	6.340	6.639	11 1/4	11.170	11.320
4	4.000	6 1/8	5.925	6.125	6.754	7.072	12	11.920	12.080
4 1/4	4.250	6 1/2	6.288	6.500	7.168	7.506	12 3/4	12.670	12.830
4 1/2	4.500	6 7/8	6.650	6.875	7.581	7.939	13 1/2	13.420	13.580
4 3/4	4.750	7 1/4	7.012	7.250	7.994	8.372	14 1/4	14.160	14.340
5	5.000	7 5/8	7.375	7.625	8.408	8.805	15	14.910	15.090
5 1/4	5.250	8	7.738	8.000	8.821	9.238	15 3/4	15.650	15.850
5 1/2	5.500	8 3/8	8.100	8.375	9.234	9.671	16 1/2	16.400	16.600
5 3/4	5.750	8 3/4	8.462	8.750	9.647	10.104	17 1/4	17.150	17.350
6	6.000	9 1/8	8.825	9.125	10.060	10.537	18	17.890	18.110

Table 13 Dimensions of Hex Coupling Nuts (Cont'd)

GENERAL NOTES:

- (a) For additional requirements, refer to section 3, General Data.
- (b) *Concentricity of Tapped Hole*. Axis of tapped hole shall be concentric with axis of nut body within a tolerance equal to 3% (6% FIM) of the maximum width across flats.
- (c) *Countersink*. Tapped hole may be countersunk on both faces.
- (d) When specified by the purchaser, different thread sizes or series shall be tapped into the nut from opposite ends with each thread extending to approximately $0.5H$. All other nut dimensions shall comply with Table 13 unless otherwise agreed to by the supplier and purchaser.
- (e) The dimensions in Table 13 are considered standard, but purchasers may specify across flats sizes and/or lengths that differ from this Table.
- (f) Hex coupling nuts must conform to the proof load requirements of ASTM A563, Grade A for heavy hex nuts.

NOTE:

- (1) Nuts shall be furnished without a hole, unless specially ordered by the purchaser. In some applications it may be desirable to assure that the threaded parts joined by a coupling nut are each engaged to approximately one-half nut thickness. As a visual inspection aid, a hole drilled through one side of the nut is recommended. The hole should be located at mid-nut thickness, and have a diameter of 0.2 to 0.4 times nominal nut size for sizes $2\frac{1}{2}$ in. and smaller, and 1 in. for sizes $2\frac{3}{4}$ in. and larger.

MANDATORY APPENDIX I

SLOT GAGES AND GAGING FOR SLOTTED NUTS

The gages specified in Table I-1 shall be used to determine the acceptability of the alignment and bottom contours of the slots in slotted nuts in accordance with the following procedure.

The gaging for slot alignment provides for equal variations in the location of the cotter pinhole in the bolt and the location of the slots in the nut.

To inspect the nut, the slotted end of the gage shall be inserted through the threaded hole from the bearing surface of the nut. The gage pin shall then be inserted into both the gage slot and the nut slots through three

adjacent faces of the nut, consecutively. Slot alignment shall be considered satisfactory if the gage pin fits into the slots without interference at all three gaging positions. The bottom contour shall be acceptable if the gage pin contacts the bottom surfaces of opposite slots during the alignment gaging at all three positions.

Some deviations from the specified gage plug diameters, D , may be necessary to compensate for variations in the nut thread minor diameter due to differences in manufacturing practices. To ensure adequate service life, gages and gage pins shall be suitably hardened.

Table I-1 Dimensions of Slot Gages and Gage Pins

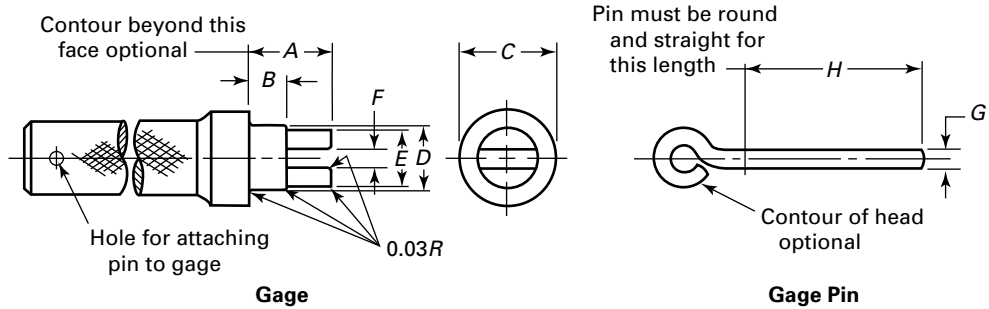

Nominal Size	Basic Major Diameter of Thread	Minimum Gage Pilot Length, A	Maximum Gage Plug Length, B	Minimum Gage Face Diameter, C	Gage Plug Diameter, D [Note (1)]		Gage Pilot Diameter, E ±0.005	Gage Slot Width, F +0.002 -0.000	Gage Pin Diameter, G +0.000 -0.002	Minimum Gage Pin Length, H
					Coarse Thread	Fine Thread				
					+0.000 -0.001	+0.000 -0.001				
1/4	0.2500	0.288	0.110	0.375	0.196	0.211	0.181	0.065	0.065	1.00
5/16	0.3125	0.316	0.150	0.406	0.252	0.267	0.237	0.085	0.085	1.06
3/8	0.3750	0.415	0.180	0.500	0.307	0.330	0.292	0.115	0.115	1.19
7/16	0.4375	0.463	0.200	0.562	0.360	0.383	0.345	0.115	0.115	1.25
1/2	0.5000	0.573	0.260	0.625	0.417	0.446	0.402	0.145	0.145	1.38
9/16	0.5625	0.621	0.280	0.703	0.472	0.502	0.457	0.145	0.145	1.44
5/8	0.6250	0.731	0.310	0.781	0.527	0.565	0.512	0.175	0.175	1.56
3/4	0.7500	0.827	0.370	0.938	0.642	0.682	0.627	0.175	0.175	1.75
7/8	0.8750	0.922	0.480	1.109	0.755	0.798	0.740	0.175	0.175	1.94
1	1.0000	1.018	0.550	1.250	0.865	0.910	0.850	0.235	0.235	2.12
1 1/8	1.1250	1.176	0.600	1.406	0.970	1.035	0.955	0.235	0.235	2.31
1 1/4	1.2500	1.272	0.660	1.562	1.095	1.160	1.080	0.305	0.305	2.50
1 3/8	1.3750	1.399	0.770	1.718	1.195	1.285	1.180	0.305	0.305	2.69
1 1/2	1.5000	1.526	0.810	1.875	1.320	1.410	1.305	0.365	0.365	2.88
1 3/4	1.7500	1.759	1.190	2.188	1.534	...	1.519	0.425	0.425	3.25
2	2.0000	2.013	1.370	2.500	1.759	...	1.744	0.425	0.425	3.62
2 1/4	2.2500	2.251	1.610	2.818	2.009	...	1.994	0.425	0.425	4.00
2 1/2	2.5000	2.505	1.730	3.125	2.229	...	2.214	0.545	0.545	4.38
2 3/4	2.7500	2.759	1.980	3.438	2.479	...	2.464	0.545	0.545	4.75
3	3.0000	3.013	2.160	3.750	2.729	...	2.714	0.615	0.615	5.12
3 1/4	3.2500	3.252	2.400	4.062	2.979	...	2.964	0.615	0.615	5.50
3 1/2	3.5000	3.506	2.640	4.375	3.229	...	3.214	0.615	0.615	5.88
3 3/4	3.7500	3.760	2.890	4.688	3.479	...	3.464	0.615	0.615	6.25
4	4.0000	4.014	3.140	5.000	3.729	...	3.714	0.615	0.615	6.62

NOTE:

- (1) Diameters tabulated are equivalent to the minimum minor diameters of Class 2B threads. If the nuts are not threaded with unified coarse (UNC) or fine (UNF) threads, the diameter of gage shall be the same as the diameter of the GO thread plug gage for the bore.

NONMANDATORY APPENDIX A FORMULAS FOR NUT DIMENSIONS

Table A-1 specifies formulas for various nut dimensions.

.....

Table A-1 Formulas for Nut Dimensions

Nut Type	Nut Size	Width Across Flats		Nut Thickness		Width Across Corners	
		Basic [Note (1)]	Tolerance (Minus)	Basic [Note (2)]	Tolerance (Plus or Minus)	Limits, <i>G</i>	
						Min.	Max.
Square	$\frac{1}{4}$ to $\frac{5}{8}$	$F = 1.500D + 0.062$	$0.050D$	$H = 0.875D$	$0.016D + 0.012$	$1.373 \times (\text{Min. } F) - 0.030$	$1.4142 \times (\text{Max. } F)$
	$\frac{3}{4}$ to $1\frac{1}{2}$	$F = 1.500D$	$0.050D$	$H = 0.875D$	$0.016D + 0.012$	$1.373 \times (\text{Min. } F) - 0.030$	$1.4142 \times (\text{Max. } F)$
Hex Flat	$1\frac{1}{8}$ to $1\frac{1}{2}$	$F = 1.500D$	$0.050D$	$H = 0.875D$	$0.016D + 0.012$	$1.14 \times (\text{Min. } F)$	$1.1547 \times (\text{Max. } F)$
Hex Flat Jam	$1\frac{1}{8}$	$F = 1.500D$	$0.050D$	$H = 0.500D + 0.062$	$0.016D + 0.012$	$1.14 \times (\text{Min. } F)$	$1.1547 \times (\text{Max. } F)$
	$1\frac{1}{4}$ to $1\frac{1}{2}$	$F = 1.500D$	$0.050D$	$H = 0.500D + 0.125$	$0.016D + 0.012$	$1.14 \times (\text{Min. } F)$	$1.1547 \times (\text{Max. } F)$
Hex and Hex Slotted	$\frac{1}{4}$	$F = 1.500D + 0.062$	$0.015D + 0.006$	$H = 0.875D$	$0.015D + 0.003$	$1.14 \times (\text{Min. } F)$	$1.1547 \times (\text{Max. } F)$
	$\frac{5}{16}$ to $\frac{5}{8}$	$F = 1.500D$	$0.015D + 0.006$	$H = 0.875D$	$0.015D + 0.003$	$1.14 \times (\text{Min. } F)$	$1.1547 \times (\text{Max. } F)$
	$\frac{3}{4}$ to $1\frac{1}{8}$	$F = 1.500D$	$0.050D$	$H = 0.875D - 0.016$	$0.016D + 0.012$	$1.14 \times (\text{Min. } F)$	$1.1547 \times (\text{Max. } F)$
	$1\frac{1}{4}$ to $1\frac{1}{2}$	$F = 1.500D$	$0.050D$	$H = 0.875D - 0.031$	$0.016D + 0.012$	$1.14 \times (\text{Min. } F)$	$1.1547 \times (\text{Max. } F)$
Hex Jam	$\frac{1}{4}$	$F = 1.500D + 0.062$	$0.015D + 0.006$	$H = \text{See Table 4}$	$0.015D + 0.003$	$1.14 \times (\text{Min. } F)$	$1.1547 \times (\text{Max. } F)$
	$\frac{5}{16}$ to $\frac{5}{8}$	$F = 1.500D$	$0.015D + 0.006$	$H = \text{See Table 4}$	$0.015D + 0.003$	$1.14 \times (\text{Min. } F)$	$1.1547 \times (\text{Max. } F)$
	$\frac{3}{4}$ to $1\frac{1}{8}$	$F = 1.500D$	$0.050D$	$H = 0.500D + 0.047$	$0.016D + 0.012$	$1.14 \times (\text{Min. } F)$	$1.1547 \times (\text{Max. } F)$
	$1\frac{1}{4}$ to $1\frac{1}{2}$	$F = 1.500D$	$0.050D$	$H = 0.500D + 0.094$	$0.016D + 0.012$	$1.14 \times (\text{Min. } F)$	$1.1547 \times (\text{Max. } F)$
Hex Thick, and Hex Thick Slotted	$\frac{1}{4}$	$F = 1.500D + 0.062$	$0.015D + 0.006$	$H = \text{See Table 6 or 7}$	$0.015D + 0.003$	$1.14 \times (\text{Min. } F)$	$1.1547 \times (\text{Max. } F)$
	$\frac{5}{16}$ to $\frac{5}{8}$	$F = 1.500D$	$0.015D + 0.006$	$H = \text{See Table 6 or 7}$	$0.015D + 0.003$	$1.14 \times (\text{Min. } F)$	$1.1547 \times (\text{Max. } F)$
	$\frac{3}{4}$ to $1\frac{1}{2}$	$F = 1.500D$	$0.050D$	$H = \text{See Table 6 or 7}$	$0.015D + 0.003$	$1.14 \times (\text{Min. } F)$	$1.1547 \times (\text{Max. } F)$
Heavy Square	$\frac{1}{4}$ to $1\frac{1}{2}$	$F = 1.500D + 0.125$	$0.050D$	$H = 1.000D$	$0.016D + 0.012$ [Note (3)]	$1.373 \times (\text{Min. } F) - 0.030$	$1.4142 \times (\text{Max. } F)$
Heavy Hex Flat	$1\frac{1}{8}$ to 4	$F = 1.500D + 0.125$	$0.050D$	$H = 1.000D$	$0.016D + 0.012$ [Note (3)]	$1.14 \times (\text{Min. } F)$	$1.1547 \times (\text{Max. } F)$
Heavy Hex Flat Jam	$\frac{1}{4}$ to $1\frac{1}{8}$	$F = 1.500D + 0.125$	$0.050D$	$H = 0.500D + 0.062$	$0.016D + 0.012$ [Note (4)]	$1.14 \times (\text{Min. } F)$	$1.1547 \times (\text{Max. } F)$
	$1\frac{1}{4}$ to $2\frac{1}{4}$	$F = 1.500D + 0.125$	$0.050D$	$H = 0.500D + 0.125$	$0.016D + 0.012$ [Note (4)]	$1.14 \times (\text{Min. } F)$	$1.1547 \times (\text{Max. } F)$
	$2\frac{1}{2}$ to 4	$F = 1.500D + 0.125$	$0.050D$	$H = 0.500D + 0.250$	$0.016D + 0.012$ [Note (4)]	$1.14 \times (\text{Min. } F)$	$1.1547 \times (\text{Max. } F)$

Table A-1 Formulas for Nut Dimensions (Cont'd)

Nut Type	Nut Size	Width Across Flats		Nut Thickness		Width Across Corners	
		Basic [Note (1)]	Tolerance (Minus)	Basic [Note (2)]	Tolerance (Plus or Minus)	Limits, <i>G</i>	
						Min.	Max.
Heavy Hex and Heavy Hex Slotted	$\frac{1}{4}$ to $1\frac{1}{8}$	$F = 1.500D + 0.125$	$0.050D$	$H = 1.000D - 0.016$	$0.016D + 0.012$	$1.14 \times (\text{Min. } F)$	$1.1547 \times (\text{Max. } F)$
	$1\frac{1}{4}$ to 2	$F = 1.500D + 0.125$	$0.050D$	$H = 1.000D - 0.031$	$0.016D + 0.012$	$1.14 \times (\text{Min. } F)$	$1.1547 \times (\text{Max. } F)$
	$2\frac{1}{4}$ to 3	$F = 1.500D + 0.125$	$0.050D$	$H = 1.000D - 0.047$	$0.016D + 0.012$	$1.14 \times (\text{Min. } F)$	$1.1547 \times (\text{Max. } F)$
	$3\frac{1}{4}$ to 4	$F = 1.500D + 0.125$	$0.050D$	$H = 1.000D - 0.062$	$0.016D + 0.012$	$1.14 \times (\text{Min. } F)$	$1.1547 \times (\text{Max. } F)$
Heavy Hex Jam	$\frac{1}{4}$ to $1\frac{1}{8}$	$F = 1.500D + 0.125$	$0.050D$	$H = 0.500D + 0.047$	$0.016D + 0.012$	$1.14 \times (\text{Min. } F)$	$1.1547 \times (\text{Max. } F)$
	$1\frac{1}{4}$ to 2	$F = 1.500D + 0.125$	$0.050D$	$H = 0.500D + 0.094$	$0.016D + 0.012$	$1.14 \times (\text{Min. } F)$	$1.1547 \times (\text{Max. } F)$
	$2\frac{1}{4}$	$F = 1.500D + 0.125$	$0.050D$	$H = 0.500D + 0.078$	$0.016D + 0.012$	$1.14 \times (\text{Min. } F)$	$1.1547 \times (\text{Max. } F)$
	$2\frac{1}{2}$ to 3	$F = 1.500D + 0.125$	$0.050D$	$H = 0.500D + 0.203$	$0.016D + 0.012$	$1.14 \times (\text{Min. } F)$	$1.1547 \times (\text{Max. } F)$
	$3\frac{1}{4}$ to 4	$F = 1.500D + 0.125$	$0.050D$	$H = 0.500D + 0.188$	$0.016D + 0.012$	$1.14 \times (\text{Min. } F)$	$1.1547 \times (\text{Max. } F)$

GENERAL NOTE: D = nominal nut size or basic diameter of the thread, F = width across flats, and G = width across corners.

NOTES:

- (1) Adjusted to sixteenths.
- (2) $\frac{1}{4}$ in. to 1 in. sizes adjusted to sixty-fourths. $1\frac{1}{8}$ in. to $2\frac{1}{2}$ in. sizes adjusted upward to thirty-seconds. $2\frac{3}{4}$ in. to 4 in. sizes adjusted upward to sixteenths.
- (3) Plus tolerance only. Minus tolerance adjusted so that minimum thickness is equal to minimum thickness of heavy hex nut.
- (4) Plus tolerance only. Minus tolerance adjusted so that minimum thickness is equal to minimum thickness of heavy hex jam nut.

NONMANDATORY APPENDIX B WRENCH OPENINGS FOR SQUARE AND HEX NUTS

Table B-1 specifies wrench openings for square and hex nuts.

Table B-1 Wrench Openings for Square and Hex Nuts

Basic Size of Wrench, <i>W</i>	Maximum Nut Across Flats [Note (1)]	Allowance Between Nut Flats and Wrench Jaws [Note (2)]	Wrench Openings			Machine Screw Nuts	Nominal Nut Sizes			
			Min.	Tolerance [Note (2)]			Square Nuts	Hex Flat, Hex Flat Jam, Hex, Hex Jam, Hex Slotted, Hex Thick, Hex Thick Slotted, Heavy Hex Slotted	Heavy Square, Heavy Hex Flat, Heavy Hex Flat Jam, Heavy Hex, Heavy Hex Jam	
				Max.						
5/32	0.156	0.002	0.158	0.005	0.163	#0, #1	
3/16	0.188	0.002	0.190	0.005	0.195	#2, #3	
1/4	0.250	0.002	0.252	0.005	0.257	#4	
5/16	0.312	0.003	0.315	0.006	0.321	#5, #6	
11/32	0.344	0.003	0.347	0.006	0.353	#8	
3/8	0.375	0.003	0.378	0.006	0.384	#10	
7/16	0.438	0.003	0.440	0.006	0.446	#12, 1/4	1/4	1/4	...	
1/2	0.500	0.004	0.504	0.006	0.510	5/16	1/4	
9/16	0.562	0.004	0.566	0.007	0.573	5/16	5/16	3/8	5/16	
5/8	0.625	0.004	0.629	0.007	0.636	3/8	3/8	
11/16	0.688	0.004	0.692	0.007	0.699	7/16	3/8	
3/4	0.750	0.005	0.755	0.008	0.763	...	7/16	1/2	7/16	
13/16	0.813	0.005	0.818	0.008	0.826	...	1/2	
7/8	0.875	0.005	0.880	0.008	0.888	9/16	1/2	
15/16	0.938	0.006	0.944	0.009	0.953	5/8	9/16	
1	1.000	0.006	1.006	0.009	1.015	...	5/8	
1 1/16	1.063	0.006	1.068	0.009	1.077	5/8	
1 1/8	1.125	0.007	1.132	0.010	1.142	...	3/4	3/4	...	
1 1/4	1.250	0.007	1.257	0.010	1.267	3/4	
1 5/16	1.313	0.008	1.320	0.011	1.331	...	7/8	7/8	...	
1 7/16	1.438	0.008	1.446	0.011	1.457	7/8	
1 1/2	1.500	0.008	1.508	0.012	1.520	...	1	1	...	
1 5/8	1.625	0.009	1.634	0.012	1.646	1	
1 11/16	1.688	0.009	1.696	0.012	1.708	...	1 1/8	1 1/8	...	
1 13/16	1.813	0.010	1.822	0.013	1.835	1 1/8	
1 7/8	1.875	0.010	1.885	0.013	1.898	...	1 1/4	1 1/4	...	
2	2.000	0.011	2.011	0.014	2.025	1 1/4	
2 1/16	2.063	0.011	2.074	0.014	2.088	...	1 3/8	1 3/8	...	
2 3/16	2.188	0.012	2.200	0.015	2.215	1 3/8	
2 1/4	2.250	0.012	2.262	0.015	2.277	...	1 1/2	1 1/2	...	
2 3/8	2.375	0.013	2.388	0.016	2.404	1 1/2	
2 9/16	2.563	0.014	2.576	0.017	2.593	1 5/8	
2 3/4	2.750	0.014	2.766	0.017	2.783	1 3/4	
2 15/16	2.938	0.016	2.954	0.019	2.973	7/8	
3 1/8	3.125	0.017	3.142	0.020	3.162	2	
3 1/2	3.500	0.019	3.518	0.022	3.540	2 1/4	
3 7/8	3.875	0.020	3.895	0.023	3.918	2 1/2	
4 1/4	4.250	0.022	4.272	0.025	4.297	2 3/4	
4 5/8	4.625	0.024	4.649	0.027	4.676	3	
5	5.000	0.026	5.026	0.029	5.055	3 1/4	
5 3/8	5.375	0.028	5.403	0.031	5.434	3 1/2	
5 3/4	5.750	0.030	5.780	0.033	5.813	3 3/4	
6 1/8	6.125	0.032	6.157	0.035	6.192	4	

NOTES:

- (1) Wrenches are normally marked with "Basic Wrench Size," which corresponds to the basic (maximum, in most cases) width across flats dimension of the respective nut. For specific requirements applicable to wrenches, refer to the appropriate ASME B107 standard, which covers the particular wrench type.
- (2) Allowance (minimum clearance) between maximum width across flats of the nut and jaws of wrench equals $(0.005W + 0.001)$. Tolerance on wrench opening equals plus $(0.005W + 0.004)$ from minimum, where W = nominal size of wrench.

NONMANDATORY APPENDIX C

PROCEDURE FOR MEASURING BEARING SURFACE RUNOUT

The requirements for the runout feature (see Fig. C-1) are designated in Tables 1 through 12. The simplest way to determine if a nut is within its required runout is as follows:

(a) *Nut Runout Measuring Equipment*

(1) A "reversible" GO threaded plug gage with centers in both ends. Normally the class of thread for the GO plug gage is 2B.

(2) Bench center device or a lathe with a tail stock and live centers held in the chuck and tail stock.

(3) Test indicator with increments no greater than 10% of the required FIM.

(b) *Nut Runout Measurement Procedure (see Fig. C-2)*

(1) Screw the GO gage into the nut.

(2) Place the GO gage between centers.

(3) Place the indicator on outer edge of the nut bearing surface.

(4) Rotate the nut 360 deg and record the full indicator movement (FIM).

Fig. C-1 Representation of Nut Bearing Surface Runout

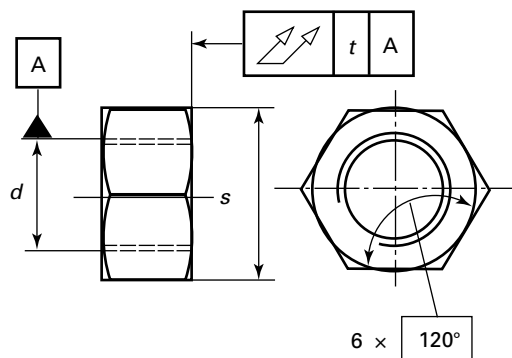
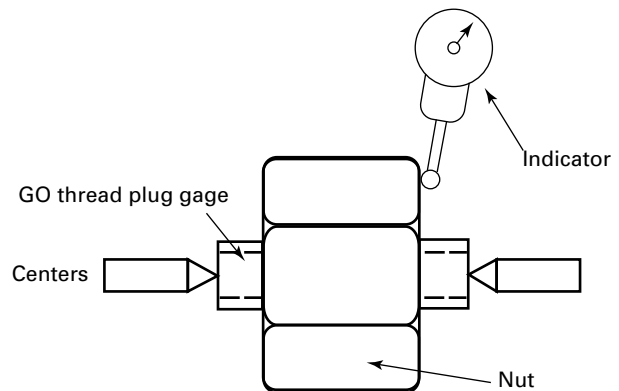

Fig. C-2 Method for the Measuring of Nut Bearing Surface Runout to Nut Pitch Diameter



B18 AMERICAN NATIONAL STANDARDS FOR BOLTS, NUTS, RIVETS, SCREWS, WASHERS, AND SIMILAR FASTENERS

Small Solid Rivets	B18.1.1-1972 (R2011)
Large Rivets	B18.1.2-1972 (R2011)
Metric Small Solid Rivets	B18.1.3M-1983 (R2011)
Square, Hex, Heavy Hex, and Askew Head Bolts and Hex, Heavy Hex, Hex Flange, Lobed Head, and Lag Screws (Inch Series)	B18.2.1-2012
Nuts for General Applications: Machine Screw Nuts, Hex, Square, Hex Flange, and Coupling Nuts (Inch Series)	B18.2.2-2015
Metric Heavy Hex Screws	B18.2.3.3M-2007 (R2014)
Metric Hex Flange Screws	B18.2.3.4M-2001 (R2011)
Metric Hex Bolts	B18.2.3.5M-1979 (R2011)
Metric Heavy Hex Flange Screws	B18.2.3.9M-2001 (R2014)
Metric Slotted Hex Nuts	B18.2.4.3M-1979 (R2012)
Metric 12-Point Flange Head Screws	B18.2.5M-2013
Metric Fasteners for Use in Structural Applications	B18.2.6M-2012
Clearance Holes for Bolt, Screws, and Studs	B18.2.8-1999 (R2010)
Straightness Gage and Gaging for Bolts and Screws	B18.2.9-2010
Socket Cap, Shoulder, Set Screws, and Hex Keys (Inch Series)	B18.3-2012
Round Head Bolts (Inch Series)	B18.5-2012
Metric Round Head Short Square Neck Bolts	B18.5.2.1M-2006 (R2011)
Wood Screws (Inch Series)	B18.6.1-1981 (R2008)
Slotted Head Cap Screws, Square Head Set Screws, and Slotted Headless Set Screws (Inch Series)	B18.6.2-1998 (R2010)
Machine Screws, Tapping Screws, and Metallic Drive Screws (Inch Series)	B18.6.3-2013
Metric Thread-Forming and Thread-Cutting Tapping Screws	B18.6.5M-2000 (R2010)
Metric Machine Screws	B18.6.7M-1999 (R2010)
Thumb Screws and Wing Screws (Inch Series)	B18.6.8-2010
Wing Nuts (Inch Series)	B18.6.9-2010
General Purpose Semi-Tubular Rivets, Full Tubular Rivets, Split Rivets and Rivet Caps	B18.7-2007 (R2012)
Metric General Purpose Semi-Tubular Rivets	B18.7.1M-2007 (R2012)
Clevis Pins and Cotter Pins (Inch Series)	B18.8.1-2014
Taper Pins, Dowel Pins, Straight Pins, Grooved Pins, and Spring Pins (Inch Series)	B18.8.2-2000 (R2010)
Plow Bolts	B18.9-2012
Track Bolts and Nuts	B18.10-2006 (R2011)
Miniature Screws	B18.11-1961 (R2010)
Glossary of Terms for Mechanical Fasteners	B18.12-2012
Screw and Washer Assemblies — Sems (Inch Series)	B18.13-1996 (R2013)
Screw and Washer Assemblies: SEMS (Metric Series)	B18.13.1M-2011
Forged Eyebolts	B18.15-2015
Prevailing-Torque Type Steel Metric Hex Nuts and Hex Flange Nuts	B18.16M-2004 (R2009)
Serrated Hex Flange Locknuts 90,000 psi (Inch Series)	B18.16.4-2008 (R2013)
Prevailing Torque Locknuts (Inch Series)	B18.16.6-2014
Quality Assurance for Fasteners	B18.18-2011
Washers: Helical Spring-Lock, Tooth Lock, and Plain Washers (Inch Series)	B18.21.1-2009
Lock Washers (Metric Series)	B18.21.2M-1999 (R2014)
Double Coil Helical Spring Lock Washers for Wood Structures	B18.21.3-2008 (R2013)
Metric Plain Washers	B18.22M-1981 (R2010)
Part Identifying Number (PIN) Code System for B18 Fastener Products	B18.24-2015
Tapered and Reduced Cross Section Retaining Rings (Inch Series)	B18.27-1998 (R2011)
Helical Coil Screw Thread Inserts — Free Running and Screw Locking (Inch Series)	B18.29.1-2010
Helical Coil Screw Thread Inserts: Free Running and Screw Locking (Metric Series)	B18.29.2M-2005 (R2010)
Metric Continuous and Double-End Studs	B18.31.1M-2008
Continuous Thread Stud, Double-End Stud, and Flange Bolting Stud (Stud Bolt) (Inch Series)	B18.31.2-2014
Threaded Rods (Inch Series)	B18.31.3-2014
Threaded Rod (Metric Series)	B18.31.4M-2009
Bent Bolts (Inch Series)	B18.31.5-2011

The ASME Publications Catalog shows a complete list of all the Standards published by the Society. For a complimentary catalog, or the latest information about our publications, call 1-800-THE-ASME (1-800-843-2763).

ASME Services

ASME is committed to developing and delivering technical information. At ASME's Customer Care, we make every effort to answer your questions and expedite your orders. Our representatives are ready to assist you in the following areas:

ASME Press
Codes & Standards
Credit Card Orders
IMEchE Publications
Meetings & Conferences
Member Dues Status

Member Services & Benefits
Other ASME Programs
Payment Inquiries
Professional Development
Short Courses
Publications

Public Information
Self-Study Courses
Shipping Information
Subscriptions/Journals/Magazines
Symposia Volumes
Technical Papers

How can you reach us? It's easier than ever!

There are four options for making inquiries* or placing orders. Simply mail, phone, fax, or E-mail us and a Customer Care representative will handle your request.

Mail
ASME
150 Clove Road, 6th Floor
Little Falls, New Jersey
07424-2138

Call Toll Free
US & Canada: 800-THE-ASME
(800-843-2763)
Mexico: 95-800-THE-ASME
(95-800-843-2763)

Fax—24 hours
973-882-1717
973-882-5155

E-Mail—24 hours
customercare@asme.org

* Customer Care staff are not permitted to answer inquiries about the technical content of this code or standard. Information as to whether or not technical inquiries are issued to this code or standard is shown on the copyright page. All technical inquiries must be submitted in writing to the staff secretary. Additional procedures for inquiries may be listed within.

ASME B18.2.2-2015

ISBN 978-0-7918-7032-7



M04315