

ASME B16.48-2015
(Revision of ASME B16.48-2010)

Line Blanks

AN AMERICAN NATIONAL STANDARD



The American Society of
Mechanical Engineers

ASME B16.48-2015
(Revision of ASME B16.48-2010)

Line Blanks

AN AMERICAN NATIONAL STANDARD



**The American Society of
Mechanical Engineers**

Two Park Avenue • New York, NY • 10016 USA

Date of Issuance: December 29, 2015

The next edition of this Standard is scheduled for publication in 2020.

ASME issues written replies to inquiries concerning interpretations of technical aspects of this Standard. Periodically certain actions of the ASME B16 Committee may be published as Cases. Cases and interpretations are published on the ASME Web site under the Committee Pages at <http://cstools.asme.org/> as they are issued.

Errata to codes and standards may be posted on the ASME Web site under the Committee Pages to provide corrections to incorrectly published items, or to correct typographical or grammatical errors in codes and standards. Such errata shall be used on the date posted.

The Committee Pages can be found at <http://cstools.asme.org/>. There is an option available to automatically receive an e-mail notification when errata are posted to a particular code or standard. This option can be found on the appropriate Committee Page after selecting “Errata” in the “Publication Information” section.

ASME is the registered trademark of The American Society of Mechanical Engineers.

This code or standard was developed under procedures accredited as meeting the criteria for American National Standards. The Standards Committee that approved the code or standard was balanced to assure that individuals from competent and concerned interests have had an opportunity to participate. The proposed code or standard was made available for public review and comment that provides an opportunity for additional public input from industry, academia, regulatory agencies, and the public-at-large.

ASME does not “approve,” “rate,” or “endorse” any item, construction, proprietary device, or activity.

ASME does not take any position with respect to the validity of any patent rights asserted in connection with any items mentioned in this document, and does not undertake to insure anyone utilizing a standard against liability for infringement of any applicable letters patent, nor assumes any such liability. Users of a code or standard are expressly advised that determination of the validity of any such patent rights, and the risk of infringement of such rights, is entirely their own responsibility.

Participation by federal agency representative(s) or person(s) affiliated with industry is not to be interpreted as government or industry endorsement of this code or standard.

ASME accepts responsibility for only those interpretations of this document issued in accordance with the established ASME procedures and policies, which precludes the issuance of interpretations by individuals.

No part of this document may be reproduced in any form,
in an electronic retrieval system or otherwise,
without the prior written permission of the publisher.

The American Society of Mechanical Engineers
Two Park Avenue, New York, NY 10016-5990

Copyright © 2015 by
THE AMERICAN SOCIETY OF MECHANICAL ENGINEERS
All rights reserved
Printed in U.S.A.

CONTENTS

Foreword	iv
Committee Roster	v
Correspondence With the B16 Committee	vi
Summary of Changes	vii
1 Scope	1
2 General	1
3 Pressure–Temperature Ratings	2
4 Design	2
5 Dimensions	2
6 Materials	3
7 Marking	3
8 Paddle Blank and Spacer Identification	3
9 Testing	3
Figure	
1 Line Blanks	1
Tables	
1 Dimensions of Class 150 Blanks for Use With Raised Face Flanges	4
2 Dimensions of Class 300 Blanks for Use With Raised Face Flanges	5
3 Dimensions of Class 600 Blanks for Use With Raised Face Flanges	6
4 Dimensions of Class 900 Blanks for Use With Raised Face Flanges	7
5 Dimensions of Class 1500 Blanks for Use With Raised Face Flanges	8
6 Dimensions of Class 2500 Blanks for Use With Raised Face Flanges	9
7 Dimensions of Class 150 Female Ring-Joint Facing Figure-8 Blanks	10
8 Dimensions of Class 300 Female Ring-Joint Facing Figure-8 Blanks	11
9 Dimensions of Class 600 Female Ring-Joint Facing Figure-8 Blanks	12
10 Dimensions of Class 900 Female Ring-Joint Facing Figure-8 Blanks	13
11 Dimensions of Class 1500 Female Ring-Joint Facing Figure-8 Blanks	14
12 Dimensions of Class 2500 Female Ring-Joint Facing Figure-8 Blanks	15
13 Dimensions of Class 150 Male Ring-Joint Facing Figure-8 Blanks	16
14 Dimensions of Class 300 Male Ring-Joint Facing Figure-8 Blanks	17
15 Dimensions of Class 600 Male Ring-Joint Facing Figure-8 Blanks	18
16 Dimensions of Class 900 Male Ring-Joint Facing Figure-8 Blanks	19
17 Dimensions of Class 1500 Male Ring-Joint Facing Figure-8 Blanks	20
18 Dimensions of Class 2500 Male Ring-Joint Facing Figure-8 Blanks	21
Mandatory Appendices	
I Dimensional Data for Line Blanks in U.S. Customary Units	23
II References	42
Nonmandatory Appendix	
A Quality System Program	43

FOREWORD

In July 1993, the ASME B16 Committee gave to its Subcommittee C the assignment to convert the API 590 Steel Line Blanks Standard into an ASME standard. The American Petroleum Institute no longer publishes the API 590 Standard.

These line blanks were designed in accordance with the rules of the ASME B31.3-2002 edition. Materials and relevant footnotes have been added following the ASME format.

Significant additions were made to the 2005 edition that included reference to the use of all materials listed in B16.5 Table 1A plus Metric units. The added materials of construction included additions to classes of alloy steels, stainless steels, and nickel alloys. The 2005 edition was also metricated over previous editions to include both U.S. Customary units (in parentheses) and Metric units in the text, Metric units in dimensional tables in the body, and U.S. Customary units in dimensional tables in Nonmandatory Appendix A.

Following the approval of the Standards Committee and ASME, approval for the 2005 edition was granted by the American National Standards Institute (ANSI) on September 19, 2005.

The 2010 edition included revisions to paragraph numbering and adjustments of appendices. In addition to renumbering of main text, updates were made to the Materials section and Marking Method. Illustrations for the figure-8 blanks for raised face flange joints were revised. Finally, the tables for male ring-joint facing figure-8 blanks were revised to support both oval and octagonal ring shapes.

The 2015 edition includes revisions to paragraph numbering, and updates have been made to the Materials and Thickness Tolerances sections. Tables for class 300 male oval ring-joint figure-8 blanks have been updated for thickness.

All requests for interpretations or suggestions for revisions should be sent to the Secretary, B16 Committee, The American Society of Mechanical Engineers, Two Park Avenue, New York, NY 10016-5990.

The B16 Committee operates under procedures accredited by ANSI. Following approval by the Standards Committee and ASME, this revision to the 2010 edition was approved as an American National Standard by ANSI on September 18, 2015, with the designation ASME B16.48-2015.

ASME B16 COMMITTEE

Standardization of Valves, Flanges, Fittings, and Gaskets

(The following is the roster of the Committee at the time of approval of this Standard.)

STANDARDS COMMITTEE OFFICERS

W. B. Bedesem, *Chair*
G. A. Jolly, *Vice Chair*
C. E. O'Brien, *Secretary*

STANDARDS COMMITTEE PERSONNEL

A. Appleton , Alloy Stainless Products Co., Inc.	G. A. Jolly , Flowserve
R. W. Barnes , Anric Enterprises, Inc.	M. Katcher , Haynes International
W. B. Bedesem , Consultant	T. A. McMahon , Emerson Process Management
R. Bojarczuk , ExxonMobil Research & Engineering Co.	M. L. Nayyar , NICE
D. F. Buccicone , Consultant	C. E. O'Brien , The American Society of Mechanical Engineers
A. M. Cheta , Royal Dutch Shell	W. H. Patrick , The Dow Chemical Co.
M. A. Clark , NIBCO, Inc.	R. A. Schmidt , Canadoil
G. A. Cuccio , Capitol Manufacturing Co.	H. R. Sonderegger , Consultant
C. E. Davila , Crane Energy	W. M. Stephan , Flexitallic LP
D. R. Frikken , Becht Engineering Co.	F. R. Volgstadt , Volgstadt & Associates, Inc.
R. P. Griffiths , Consultant	D. A. Williams , Southern Co. Generation

SUBCOMMITTEE C — STEEL FLANGES AND FLANGED FITTINGS

C. E. Davila , <i>Chair</i> , Crane Energy	J. R. Holstrom , Val-Matic Valve & Manufacturing Corp.
J. P. Ellenberger , <i>Vice Chair</i> , Consultant	M. Katcher , Haynes International
A. P. Maslowski , <i>Secretary</i> , The American Society of Mechanical Engineers	M. L. Nayyar , NICE
A. Appleton , Alloy Stainless Products Co., Inc.	W. H. Patrick , The Dow Chemical Co.
W. B. Bedesem , Consultant	D. W. Raho , Consultant
W. J. Birkholz , Flowline Division, Ezeflow USA, Inc.	T. V. Ramakrishnan , Forged Components, Inc.
A. M. Cheta , Royal Dutch Shell	R. A. Schmidt , Canadoil
B. Dennis , Kerkau Manufacturing	D. E. Tezzo , Tyco Valves & Controls
D. R. Frikken , Becht Engineering Co.	J. P. Tucker , Flowserve
E. Gulgun , International Standard Valve, Inc.	G. T. Walden , Wolseley
	M. M. Zaidi , Jacobs Engineering
	G. B. Hailegiorgis , <i>Contributing Member</i> , Ameriforge Group, Inc.

CORRESPONDENCE WITH THE B16 COMMITTEE

General. ASME Standards are developed and maintained with the intent to represent the consensus of concerned interests. As such, users of this Standard may interact with the Committee by requesting interpretations, proposing revisions or a Case, and attending Committee meetings. Correspondence should be addressed to:

Secretary, B16 Standards Committee
The American Society of Mechanical Engineers
Two Park Avenue
New York, NY 10016-5990

As an alternative, inquiries may be submitted via e-mail to SecretaryB16@asme.org.

Proposing Revisions. Revisions are made periodically to the Standard to incorporate changes that appear necessary or desirable, as demonstrated by the experience gained from the application of the Standard. Approved revisions will be published periodically.

The Committee welcomes proposals for revisions to this Standard. Such proposals should be as specific as possible, citing the paragraph number(s), the proposed wording, and a detailed description of the reasons for the proposal, including any pertinent documentation.

Proposing a Case. Cases may be issued for the purpose of providing alternative rules when justified, to permit early implementation of an approved revision when the need is urgent, or to provide rules not covered by existing provisions. Cases are effective immediately upon ASME approval and shall be posted on the ASME Committee Web page.

Requests for Cases shall provide a Statement of Need and Background Information. The request should identify the Standard and the paragraph, figure, or table number(s), and be written as a Question and Reply in the same format as existing Cases. Requests for Cases should also indicate the applicable edition(s) of the Standard to which the proposed Case applies.

Interpretations. Upon request, the B16 Standards Committee will render an interpretation of any requirement of the Standard. Interpretations can only be rendered in response to a written request sent to the Secretary of the B16 Standards Committee.

The request for an interpretation should be clear and unambiguous. It is further recommended that the inquirer submit his/her request in the following format:

Subject: Cite the applicable paragraph number(s) and the topic of the inquiry.
Edition: Cite the applicable edition of the Standard for which the interpretation is being requested.
Question: Phrase the question as a request for an interpretation of a specific requirement suitable for general understanding and use, not as a request for an approval of a proprietary design or situation. The inquirer may also include any plans or drawings that are necessary to explain the question; however, they should not contain proprietary names or information.

Requests that are not in this format may be rewritten in the appropriate format by the Committee prior to being answered, which may inadvertently change the intent of the original request.

ASME procedures provide for reconsideration of any interpretation when or if additional information that might affect an interpretation is available. Further, persons aggrieved by an interpretation may appeal to the cognizant ASME Committee or Subcommittee. ASME does not "approve," "certify," "rate," or "endorse" any item, construction, proprietary device, or activity.

Attending Committee Meetings. The B16 Standards Committee regularly holds meetings and/or telephone conferences that are open to the public. Persons wishing to attend any meeting and/or telephone conference should contact the Secretary of the B16 Standards Committee.

ASME B16.48-2015

SUMMARY OF CHANGES

Following approval by the ASME B16 Committee, and after public review, ASME B16.48-2015 was approved by the American National Standards Institute on September 18, 2015.

ASME B16.48-2015 contains editorial changes, revisions, and corrections identified by a margin note, (15), placed next to the affected area.

<i>Page</i>	<i>Location</i>	<i>Change</i>
1	2.4	Editorially revised
	2.5	Editorially revised
2	5.2.2	Data reformatted
3	6.1	Revised
17	Table 14	Under "Thickness, <i>t</i> ," ninth entry revised
37	Table I-14	Under "Thickness, <i>t</i> ," ninth entry revised

INTENTIONALLY LEFT BLANK

LINE BLANKS

1 SCOPE

This Standard covers pressure–temperature ratings, materials, dimensions, tolerances, marking, and testing for operating line blanks in sizes NPS $\frac{1}{2}$ through NPS 24 for installation between ASME B16.5 flanges in the 150, 300, 600, 900, 1500, and 2500 pressure classes.

2 GENERAL

2.1 Definitions

2.1.1 Figure-8 Blank. A figure-8 blank (also called a spectacle blank) is a pressure-retaining plate with one solid end and one open end connected with a web or tie bar (see Fig. 1).

2.1.2 Paddle Blank. A paddle blank is similar to the solid end of a figure-8 blank. It has a plain radial handle. It is generally used in conjunction with a paddle spacer in large sizes.

2.1.3 Paddle Spacer. A paddle spacer is similar to the open end of a figure-8 blank. It has a plain radial handle. It is generally used in conjunction with a paddle blank.

2.2 References

Codes, standards, and specifications, containing provisions to the extent referenced herein, constitute requirements of this Standard. These reference documents are listed in Mandatory Appendix II.

2.3 Quality Systems

Nonmandatory requirements relating to the product manufacturer's Quality System Program are described in Nonmandatory Appendix A.

2.4 Relevant Units

This Standard states values in both SI (Metric) and U.S. Customary units. These systems of units are to be regarded separately as standard. Within the text, the U.S. Customary units are shown in parentheses or in separate tables that appear in Mandatory Appendix I. The values stated in each system are not exact equivalents; therefore, it is required that each system of units be used independently of the other. Combining values from the two systems constitutes nonconformance with the Standard.

2.5 Convention

For determining conformance with this Standard, the convention for fixing significant digits where limits (maximum and minimum values) are specified shall be as defined in ASTM E29. This requires that an observed or calculated value be rounded off to the nearest unit in the last right-hand digit used for expressing the limit. Decimal values and tolerances do not imply a particular method of measurement.

2.6 Size

NPS, followed by a dimensionless number, is the designation for nominal blank size. NPS is related to the reference nominal diameter, DN, as defined in ISO 6708. The relationship is typically as follows:

NPS	DN
$\frac{1}{2}$	15
$\frac{3}{4}$	20
1	25
$1\frac{1}{4}$	32
$1\frac{1}{2}$	40
2	50
$2\frac{1}{2}$	65
3	80
4	100

GENERAL NOTE: For NPS ≥ 4 , the related DN = 25 multiplied by the NPS number.

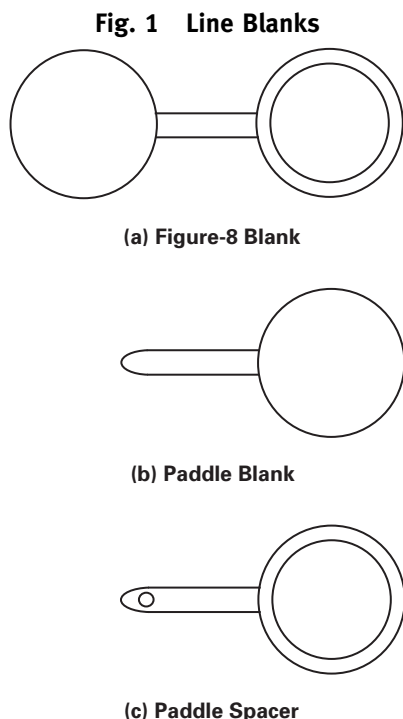

2.7 Service Conditions

Criteria for selection of materials suitable for particular fluid service are not within the scope of this Standard.

3 PRESSURE-TEMPERATURE RATINGS

3.1 Pressure Classes

Line blanks covered by this Standard are for the following pressure classes: 150, 300, 600, 900, 1500, and 2500 as listed in ASME B16.5.

3.2 Pressure-Temperature Ratings

3.2.1 Ratings. Ratings are the maximum allowable working gage pressure at the temperature shown in Tables 2 and II-2 of ASME B16.5 for the appropriate material and pressure class. For intermediate temperatures, linear interpolation between temperatures within a pressure class is permitted by ASME B16.5.

3.2.2 System Pressure Testing. Line blanks may be subjected to system tests at a pressure not to exceed 1.5 times the 38°C (100°F) rating rounded off to the next higher 1 bar (25 psi) increment. Testing at any higher pressure is the responsibility of the user, taking into account the requirements of the applicable code or regulation.

3.2.3 Mixed Material Joints. Should either the two flanges or the line blank in a flanged line blank assembly not have the same pressure-temperature rating, the rating of the assembled joint at any temperature shall be the lower of the flange or line blank rating at that temperature.

4 DESIGN

4.1 Handle

The handle or web (tie bar) may be integral or attached to the line blank or spacer. The web and its attachment shall be capable of supporting the weight of the blank or spacer in all orientations without permanent deformation to the web.

4.2 Edge Preparation

In addition to machining, flame, plasma, saw cutting, and press punching are acceptable methods for forming the inside and outside diameters of line blanks. Surfaces shall be free of projections that would interfere with gasket seating.

4.3 Facing

4.3.1 Raised Face Joint Blanks. The gasket seating surface and dimensions for line blanks used with raised face flanges shall be in accordance with ASME B16.5. A raised face may be specified for these blanks at the option of the purchaser. The height of the raised faces shall be in

addition to the thicknesses, t , listed in Tables 1 through 6 (Tables I-1 through I-6 in Mandatory Appendix I).

4.3.2 Female Ring-Joint Blanks. Female ring-joint grooves shall be shaped with the groove side wall surface finish not exceeding 1.6 μm (63 $\mu\text{in.}$) Ra roughness. The finish of the gasket contact faces shall be judged by visual comparison with Ra standards (see ASME B46.1) and not by instruments having stylus tracers and electronic amplification.

4.3.3 Male Ring-Joint Blanks. The gasket shape (ring) for male ring-joint blanks shall not exceed 1.6 μm (63 $\mu\text{in.}$) Ra roughness. The finish of the gasket contact faces shall be judged by visual comparison with Ra standards (see ASME B46.1) and not by instruments having stylus tracers and electronic amplification.

5 DIMENSIONS

5.1 General

Dimensions shall be in accordance with Tables 1 through 18 (Tables I-1 through I-18).

5.2 Tolerances

5.2.1 Facing Tolerances. Tolerances for facings shall be in accordance with ASME B16.5.

5.2.2 Thickness Tolerances. Thickness tolerances (15) are

Size	Tolerance, mm (in.)
NPS \leq 18	+3.0, -0.0 (+0.12, -0.00)
NPS \geq 20	+4.8, -0.0 (+0.19, -0.00)

5.3 Openings

(a) For NPS $\frac{1}{2}$, NPS $\frac{3}{4}$, and NPS 1 blanks in all raised face classes, the inside diameter is equal to standard weight welding neck flange bore.

(b) For NPS $1\frac{1}{4}$ and larger blanks in Classes 150 and 300 raised face, the inside diameter is equal to the pipe outside diameter.

(c) For NPS $1\frac{1}{4}$ and larger blanks in Classes 600 and 900 raised face, the inside diameter is equal to Schedule 10S welding neck flange bore.

(d) For Class 1500 raised face blanks, the inside diameter is equal to Schedule 40 welding neck flange bore.

(e) For Class 2500 raised face blanks, the inside diameter is equal to Schedule 40 through NPS 6, Schedule 60 for NPS 8 and NPS 10, and Schedule 80 for NPS 12.

(f) For all ring-joint blanks, the inside diameter is equal to the pipe outside diameter.

(g) Dimensions are based upon concentric installation of spiral wound gaskets with inner rings as required by ASME B16.20 and conform to the maximum permitted bore of ASME B16.5 welding neck flanges described in Table 16 of ASME B16.20.

5.4 Facing Finish

Facing finish shall be in accordance with ASME B16.5, para. 6.4.5.

6 MATERIALS

(15) 6.1 General

(a) Materials for line blanks shall be in accordance with ASME B16.5, Table 1A, and shall include material restrictions cited in notes to Tables 2 and II-2 of ASME B16.5. The blank and spacer portions of line blanks shall be manufactured as one piece in accordance with the applicable material specification. Assembly of multiple pieces into a blank or spacer portion by welding or other means is not permitted by this Standard. Attachment of the handle or web (tie bar) to a blank or spacer portion by welding or other means is permitted.

(b) Recommended bolting materials for flange-blank assemblies are listed in ASME B16.5, Table 1B.

(c) For materials manufactured to editions of the material specification other than those listed in Appendix III of ASME B16.5, refer to para. 6.2.

(d) Criteria for the selection of materials are not within the scope of this Standard.

6.2 Materials Manufactured to Other Editions

Materials may meet the requirements of material specification editions other than those listed in Appendix III of ASME B16.5, provided

(a) the materials are the same specification, grade, type, class, alloy, and heat-treated condition, as applicable

(b) the line blank manufacturer certifies that the requirements of the edition of the specification listed in Appendix III of ASME B16.5 have been met

7 MARKING

7.1 General

(a) Line blanks shall be marked as follows:

(1) manufacturer's name or trademark

(2) material, specification, and grade or class

(3) pressure class

(4) B16

(5) size (NPS)

(6) ring number (if applicable)

(b) Where space does not permit all of the above markings, they may be omitted in the reverse order given in para. 7.1(a).

(c) The B16 designation may be applied only when the line blank has been manufactured in full conformance with this Standard.

7.2 Marking Method

The marking shall be applied by steel stamping or other marking device that leaves a legible imprint. When marking on the blind portion of the blanks, low stress marking shall be used and shall not impinge on the gasket seating surface.

8 PADDLE BLANK AND SPACER IDENTIFICATION

8.1 Paddle Handles

In order to differentiate between an installed paddle spacer and a paddle blank, it is required that there be an externally visible distinction between the two as required by paras. 8.2 and 8.3.

8.2 Paddle Blank Handles

Handles for paddle blanks shall be solid with no openings.

8.3 Paddle Spacer Handles

Handles for paddle spacers shall have a single through indicator hole located near the end of the handle. The hole diameter shall not be less than 12 mm ($\frac{1}{2}$ in.).

9 TESTING

Line blanks are not required to be pressure tested.

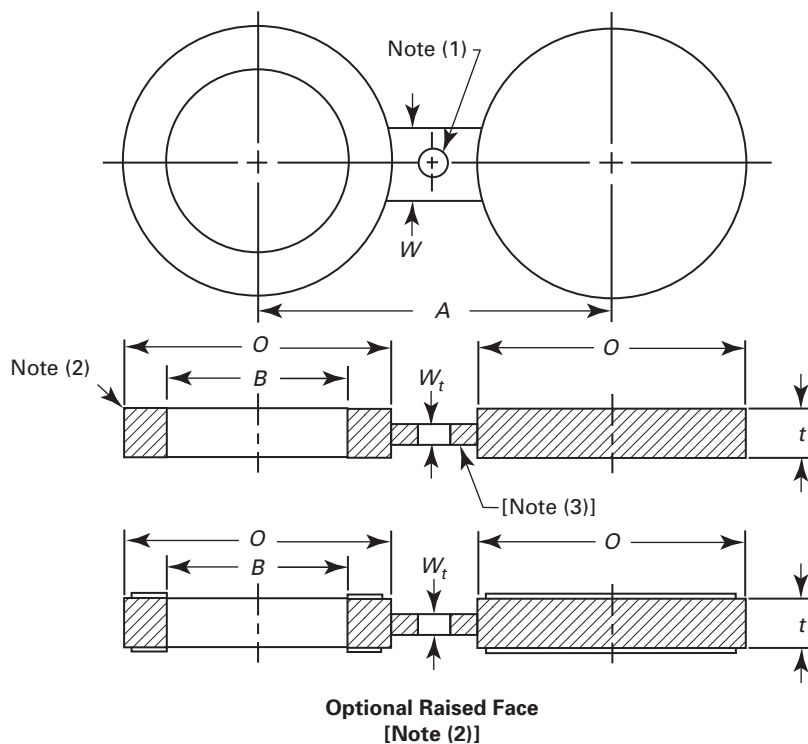
Table 1 Dimensions of Class 150 Blanks for Use With Raised Face Flanges

NPS	Inside Diameter, B, mm	Outside Diameter, O, mm	Centerline Dimension, A, mm	Thickness, t, mm	Web Width, W, mm
1/2	16	45	60	3.0	38
3/4	21	54	70	3.0	38
1	27	64	80	3.0	38
1 1/4	42	73	90	6.4	38
1 1/2	48	83	100	6.4	38
2	61	102	120	6.4	51
2 1/2	73	107	140	6.4	51
3	89	133	150	6.4	64
3 1/2	102	159	175	9.7	64
4	114	172	190	9.7	64
5	141	194	215	9.7	76
6	168	219	240	12.7	76
8	219	276	300	12.7	76
10	273	337	360	15.7	102
12	324	406	430	19.1	102
14	356	448	475	19.1	108
16	406	511	540	22.4	108
18	457	546	580	25.4	114
20	508	603	635	28.4	121
24	610	714	750	31.8	140

GENERAL NOTE: Dimensions are in millimeters. For inch dimensions, refer to corresponding Table I-1 in Mandatory Appendix I.

NOTES:

- (1) Hole size (where required due to bolt spacing) shall be the same as the flange bolt hole and located such that it will not interfere with bolting between two flanges.
- (2) Optional raised face. Refer to para. 4.3.1.
- (3) The thickness of the web (or tie bar) dimension, W_t , shall be as determined by para. 4.1.

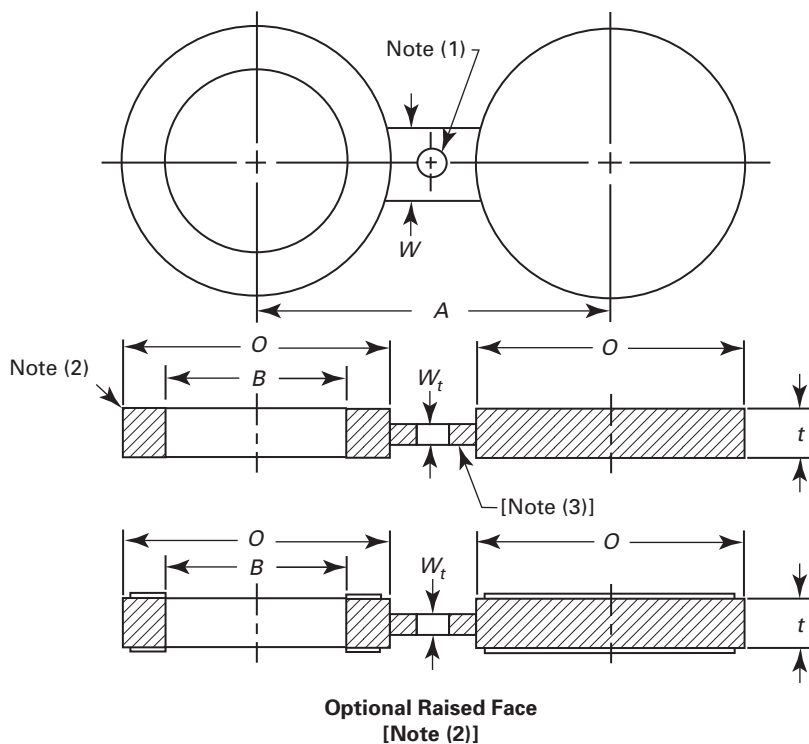
Table 2 Dimensions of Class 300 Blanks for Use With Raised Face Flanges

NPS	Inside Diameter, <i>B</i> , mm	Outside Diameter, <i>O</i> , mm	Centerline Dimension, <i>A</i> , mm	Thickness, <i>t</i> , mm	Web Width, <i>W</i> , mm
1/2	16	51	65	6.4	38
3/4	21	64	80	6.4	38
1	27	70	90	6.4	38
1 1/4	42	79	100	6.4	38
1 1/2	48	92	115	6.4	38
2	61	108	125	9.7	51
2 1/2	73	127	150	9.7	51
3	89	146	170	9.7	64
3 1/2	102	162	185	12.7	64
4	114	178	200	12.7	64
5	141	213	235	15.7	76
6	168	248	270	15.7	76
8	219	305	330	22.4	76
10	273	359	385	25.4	102
12	324	419	450	28.4	102
14	356	483	515	31.8	108
16	406	536	570	38.1	108
18	457	594	630	41.1	114
20	508	651	685	44.5	121
24	610	772	810	50.8	140

GENERAL NOTE: Dimensions are in millimeters. For inch dimensions, refer to corresponding Table I-2 in Mandatory Appendix I.

NOTES:

- (1) Hole size (where required due to bolt spacing) shall be the same as the flange bolt hole and located such that it will not interfere with bolting between two flanges.
- (2) Optional raised face. Refer to para. 4.3.1.
- (3) The thickness of the web (or tie bar) dimension, W_t , shall be as determined by para. 4.1.

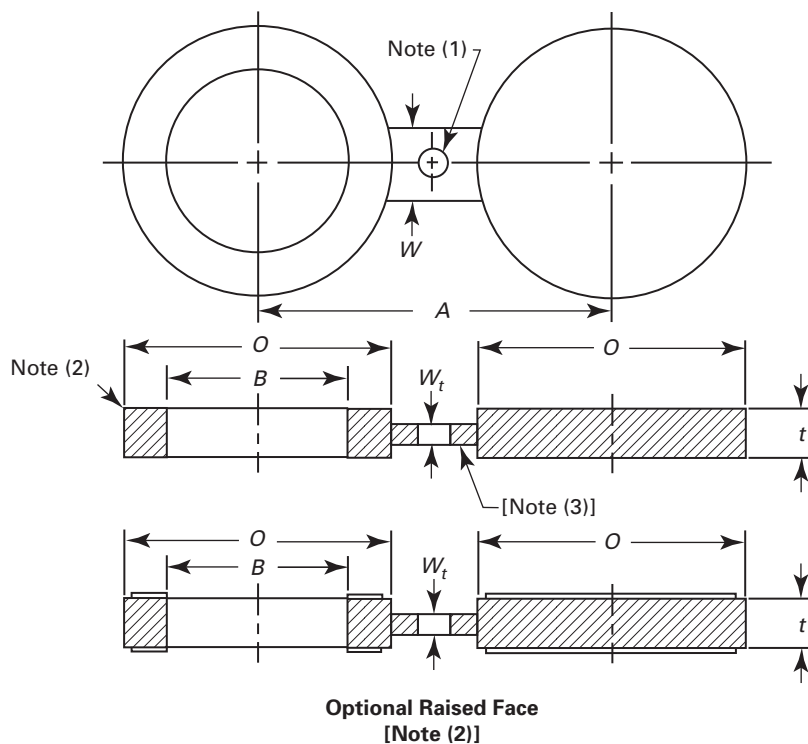
Table 3 Dimensions of Class 600 Blanks for Use With Raised Face Flanges

NPS	Inside Diameter, B, mm	Outside Diameter, O, mm	Centerline Dimension, A, mm	Thickness, t, mm	Web Width, W, mm
1/2	16	51	65	6.4	38
3/4	21	64	80	6.4	38
1	27	70	90	6.4	57
1 1/4	37	79	100	9.7	57
1 1/2	43	92	115	9.7	67
2	55	108	125	9.7	57
2 1/2	67	127	150	12.7	67
3	83	146	170	12.7	67
3 1/2	96	159	185	15.7	76
4	108	191	215	15.7	76
5	135	238	265	19.1	86
6	162	264	290	22.4	86
8	212	318	350	28.4	95
10	265	397	430	35.1	105
12	315	454	490	41.1	105
14	346	489	525	44.5	114
16	397	562	605	50.8	124
18	448	610	655	53.8	133
20	497	679	725	63.5	133
24	597	787	840	73.2	152

GENERAL NOTE: Dimensions are in millimeters. For inch dimensions, refer to corresponding Table I-3 in Mandatory Appendix I.

NOTES:

- (1) Hole size (where required due to bolt spacing) shall be the same as the flange bolt hole and located such that it will not interfere with bolting between two flanges.
- (2) Optional raised face. Refer to para. 4.3.1.
- (3) The thickness of the web (or tie bar) dimension, W_t , shall be as determined by para. 4.1.

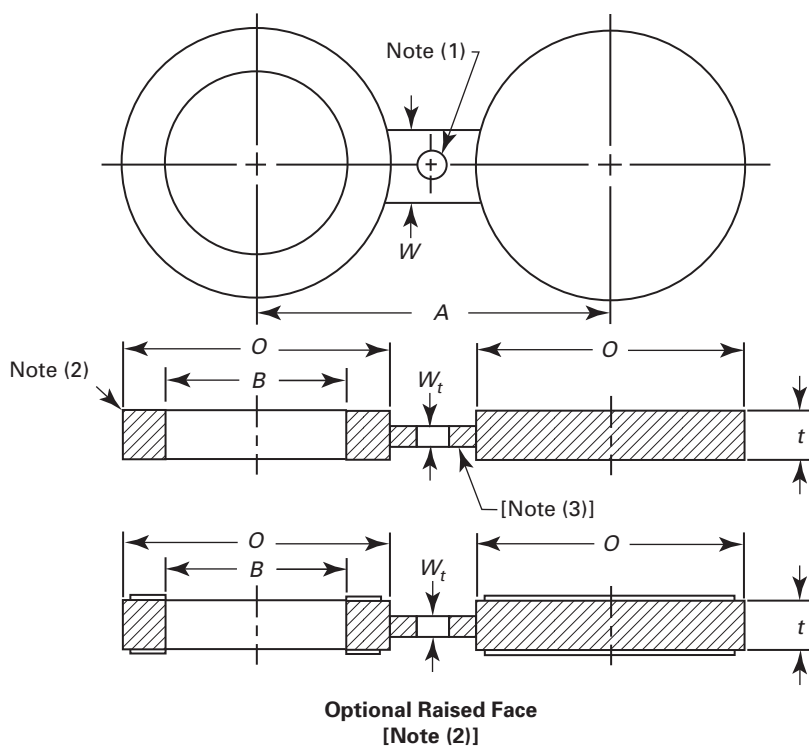
Table 4 Dimensions of Class 900 Blanks for Use With Raised Face Flanges

NPS	Inside Diameter, B, mm	Outside Diameter, O, mm	Centerline Dimension, A, mm	Thickness, t, mm	Web Width, W, mm
1/2	16	60	80	6.4	38
3/4	21	67	90	6.4	41
1	27	76	100	6.4	57
1 1/4	37	86	110	9.7	57
1 1/2	43	95	125	9.7	67
2	55	140	165	12.7	57
2 1/2	67	162	190	12.7	67
3	83	165	190	15.7	67
4	108	203	235	19.1	76
5	135	244	280	22.4	86
6	162	286	320	25.4	86
8	212	356	395	35.1	95
10	265	432	470	41.1	105
12	315	495	535	47.8	105
14	346	518	560	53.8	114
16	397	572	615	60.5	124
18	448	635	685	66.5	133
20	497	696	750	73.2	133
24	597	835	900	88.9	152

GENERAL NOTE: Dimensions are in millimeters. For inch dimensions, refer to corresponding Table I-4 in Mandatory Appendix I.

NOTES:

- (1) Hole size (where required due to bolt spacing) shall be the same as the flange bolt hole and located such that it will not interfere with bolting between two flanges.
- (2) Optional raised face. Refer to para. 4.3.1.
- (3) The thickness of the web (or tie bar) dimension, W_t , shall be as determined by para. 4.1.

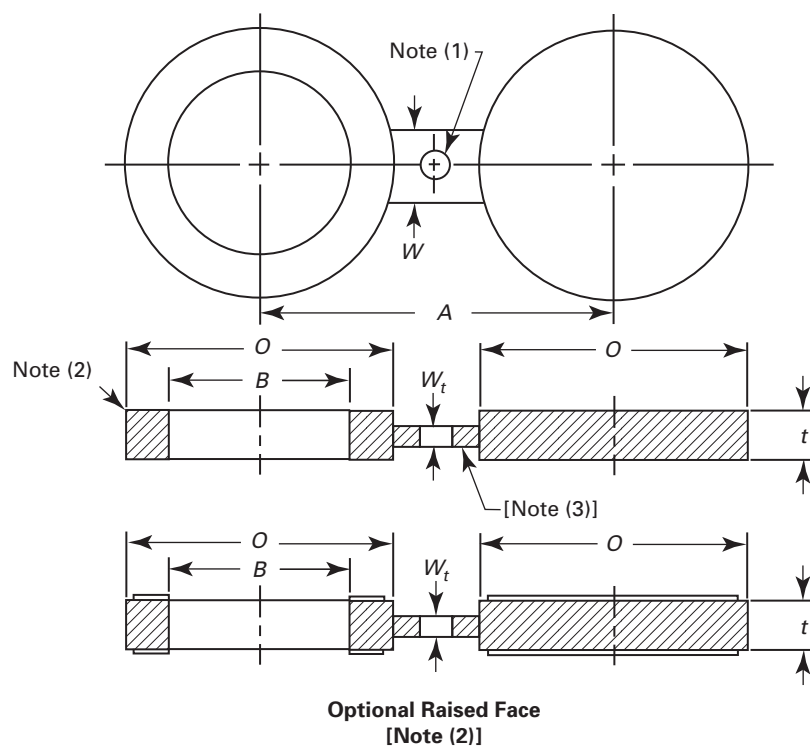
Table 5 Dimensions of Class 1500 Blanks for Use With Raised Face Flanges

NPS	Inside Diameter, B, mm	Outside Diameter, O, mm	Centerline Dimension, A, mm	Thickness, t, mm	Web Width, W, mm
1/2	16	61	80	6.4	38
3/4	21	67	90	9.7	41
1	27	76	100	9.7	64
1 1/4	35	86	110	9.7	64
1 1/2	41	95	125	12.7	70
2	53	140	165	12.7	70
2 1/2	63	162	190	15.7	76
3	78	172	205	19.1	76
4	102	206	240	22.4	89
5	128	251	290	28.4	89
6	154	279	320	35.1	89
8	203	349	395	41.1	102
10	255	432	480	50.8	114
12	303	518	570	60.5	114
14	333	575	635	66.5	127
16	381	638	705	76.2	133
18	429	702	775	85.9	146
20	478	752	830	95.3	152
24	575	899	990	111.3	178

GENERAL NOTE: Dimensions are in millimeters. For inch dimensions, refer to corresponding Table I-5 in Mandatory Appendix I.

NOTES:

- (1) Hole size (where required due to bolt spacing) shall be the same as the flange bolt hole and located such that it will not interfere with bolting between two flanges.
- (2) Optional raised face. Refer to para. 4.3.1.
- (3) The thickness of the web (or tie bar) dimension, W_t , shall be as determined by para. 4.1.

Table 6 Dimensions of Class 2500 Blanks for Use With Raised Face Flanges

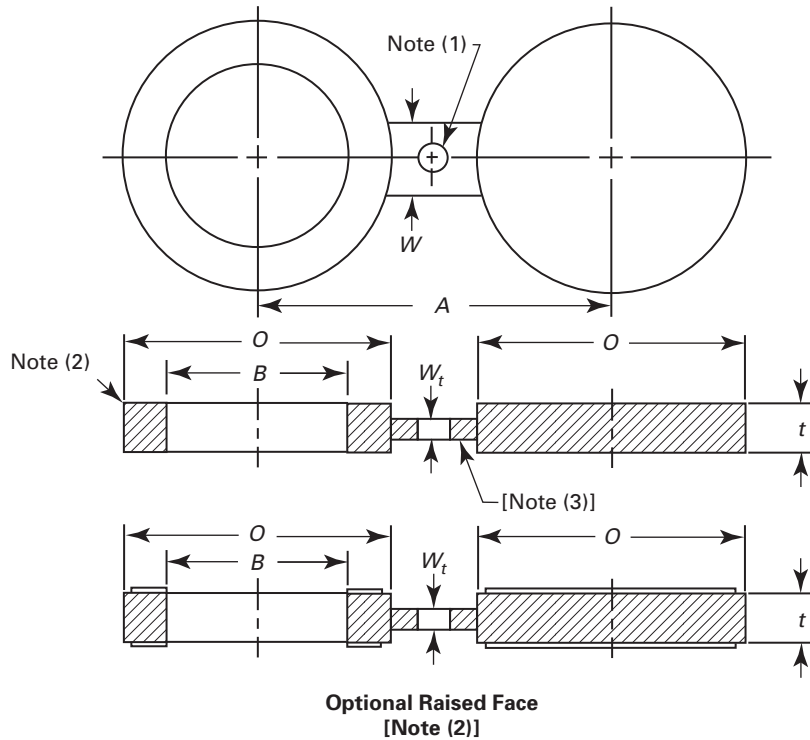

NPS	Inside Diameter, <i>B</i> , mm	Outside Diameter, <i>O</i> , mm	Centerline Dimension, <i>A</i> , mm	Thickness, <i>t</i> , mm	Web Width, <i>W</i> , mm
1/2	16	67	90	9.7	38
3/4	21	73	95	9.7	41
1	27	83	110	9.7	64
1 1/4	35	102	130	12.7	64
1 1/2	41	114	145	15.7	70
2	53	143	170	15.7	70
2 1/2	63	165	195	19.1	76
3	78	194	230	22.4	76
4	102	232	275	28.4	89
5	128	276	325	35.1	89
6	154	314	370	41.1	89
8	198	384	440	53.8	102
10	248	473	540	66.5	114
12	289	546	620	79.2	114

GENERAL NOTE: Dimensions are in millimeters. For inch dimensions, refer to corresponding Table I-6 in Mandatory Appendix I.

NOTES:

- (1) Hole size (where required due to bolt spacing) shall be the same as the flange bolt hole and located such that it will not interfere with bolting between two flanges.
- (2) Optional raised face. Refer to para. 4.3.1.
- (3) The thickness of the web (or tie bar) dimension, *W_t*, shall be as determined by para. 4.1.

Table 7 Dimensions of Class 150 Female Ring-Joint Facing Figure-8 Blanks

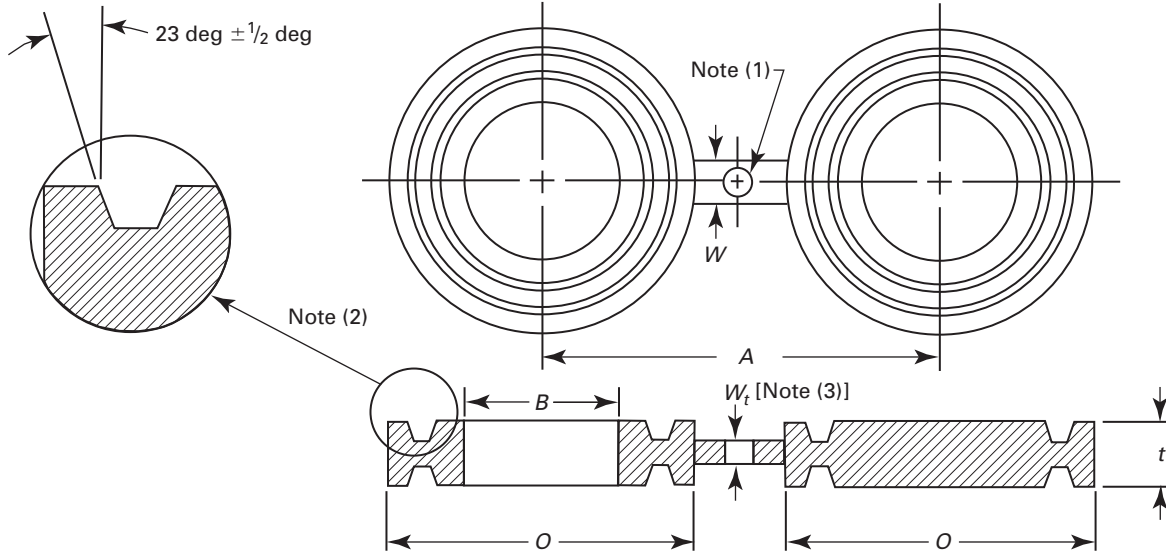

NPS	Inside Diameter, B , mm	Outside Diameter, O , mm	Centerline Dimension, A , mm	Thickness, t , mm	Web Width, W , mm
1	34	64	80	19.1	51
1 $\frac{1}{4}$	42	73	90	19.1	51
1 $\frac{1}{2}$	48	83	100	19.1	57
2	61	102	120	19.1	57
2 $\frac{1}{2}$	73	121	140	22.4	57
3	89	133	150	22.4	57
3 $\frac{1}{2}$	102	154	175	22.4	64
4	114	172	190	22.4	64
5	141	194	215	25.4	70
6	168	219	240	25.4	83
8	219	273	300	28.4	95
10	273	330	360	31.8	102
12	324	406	430	35.1	121
14	356	426	475	35.1	127
16	406	483	540	38.1	127
18	457	546	580	41.1	127
20	508	597	635	41.1	127
24	610	711	750	47.8	152

GENERAL NOTE: Dimensions are in millimeters. For inch dimensions, refer to corresponding Table I-7 in Mandatory Appendix I.

NOTES:

- (1) Hole size (where required due to bolt spacing) shall be the same as the flange bolt hole and located such that it will not interfere with bolting between two flanges.
- (2) Female ring-joint groove dimensions shall be in accordance with ASME B16.5.
- (3) The thickness of the web (or tie bar) dimension, W , shall be as determined by para. 4.1.

Table 8 Dimensions of Class 300 Female Ring-Joint Facing Figure-8 Blanks

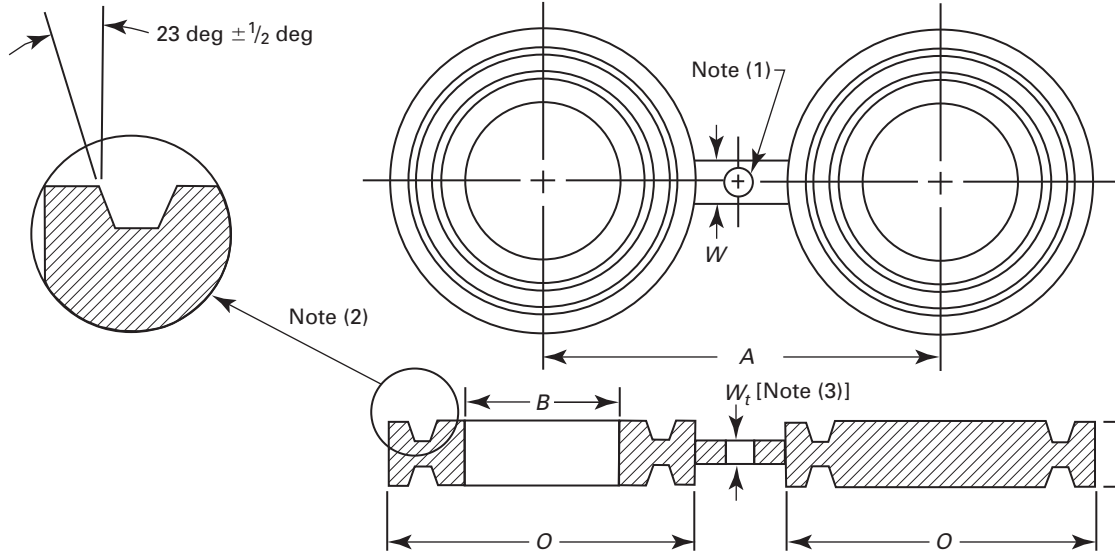

NPS	Inside Diameter, <i>B</i> , mm	Outside Diameter, <i>O</i> , mm	Centerline Dimension, <i>A</i> , mm	Thickness, <i>t</i> , mm	Web Width, <i>W</i> , mm
1/2	21	51	65	15.7	38
3/4	27	64	80	19.1	45
1	34	70	90	19.1	51
1 1/4	42	79	100	22.4	51
1 1/2	48	90	115	22.4	57
2	61	108	125	25.4	57
2 1/2	73	127	150	28.4	57
3	89	146	170	28.4	57
3 1/2	102	159	185	28.4	64
4	114	175	200	31.8	64
5	141	210	235	35.1	70
6	168	241	270	35.1	83
8	219	302	330	41.1	95
10	273	356	385	44.5	102
12	324	413	450	50.8	121
14	356	457	515	53.8	127
16	406	508	570	57.2	127
18	457	575	630	60.5	127
20	508	635	685	69.9	127
24	610	749	810	79.2	152

GENERAL NOTE: Dimensions are in millimeters. For inch dimensions, refer to corresponding Table I-8 in Mandatory Appendix I.

NOTES:

- (1) Hole size (where required due to bolt spacing) shall be the same as the flange bolt hole and located such that it will not interfere with bolting between two flanges.
- (2) Female ring-joint groove dimensions shall be in accordance with ASME B16.5.
- (3) The thickness of the web (or tie bar) dimension, W_t , shall be as determined by para. 4.1.

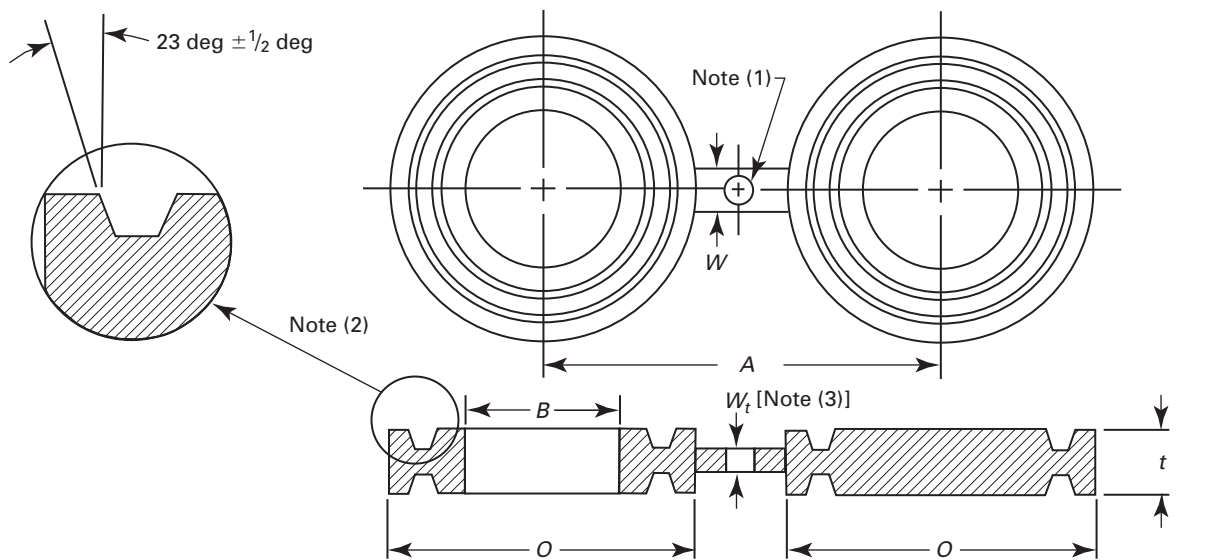
Table 9 Dimensions of Class 600 Female Ring-Joint Facing Figure-8 Blanks

NPS	Inside Diameter, B, mm	Outside Diameter, O, mm	Centerline Dimension, A, mm	Thickness, t, mm	Web Width, W, mm
1/2	21	51	65	19.1	38
3/4	27	64	80	22.4	45
1	34	70	90	22.4	51
1 1/4	42	79	100	22.4	51
1 1/2	48	90	115	22.4	57
2	61	108	125	28.4	57
2 1/2	73	127	150	31.8	57
3	89	146	170	31.8	57
3 1/2	102	159	185	35.1	64
4	114	175	215	35.1	64
5	141	210	265	38.1	70
6	168	241	290	44.5	83
8	219	302	350	50.8	95
10	273	356	430	57.2	102
12	324	413	490	63.5	121
14	356	457	525	66.5	127
16	406	508	605	73.2	127
18	457	575	655	79.2	127
20	508	635	725	88.9	127
24	610	749	840	104.6	152

GENERAL NOTE: Dimensions are in millimeters. For inch dimensions, refer to corresponding Table I-9 in Mandatory Appendix I.

NOTES:

- (1) Hole size (where required due to bolt spacing) shall be the same as the flange bolt hole and located such that it will not interfere with bolting between two flanges.
- (2) Female ring-joint groove dimensions shall be in accordance with ASME B16.5.
- (3) The thickness of the web (or tie bar) dimension, W_t , shall be as determined by para. 4.1.

Table 10 Dimensions of Class 900 Female Ring-Joint Facing Figure-8 Blanks

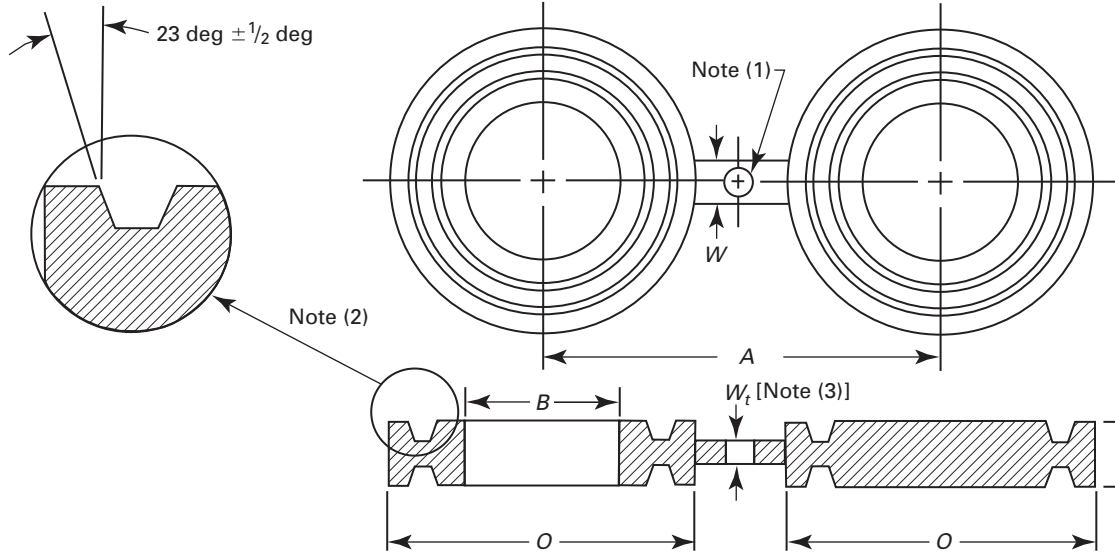

NPS	Inside Diameter, <i>B</i> , mm	Outside Diameter, <i>O</i> , mm	Centerline Dimension, <i>A</i> , mm	Thickness, <i>t</i> , mm	Web Width, <i>W</i> , mm
1/2	21	61	80	22.4	38
3/4	27	67	90	22.4	45
1	34	71	100	22.4	51
1 1/4	42	81	110	25.4	51
1 1/2	48	92	125	25.4	64
2	61	124	165	31.8	51
2 1/2	73	137	190	35.1	67
3	89	155	190	35.1	67
4	114	181	235	41.1	73
5	141	216	280	44.5	73
6	168	241	315	47.8	73
8	219	308	395	57.2	80
10	273	362	470	63.5	121
12	324	419	535	73.2	121
14	356	467	560	82.6	121
16	406	524	615	91.9	127
18	457	594	685	101.6	133
20	508	648	750	111.3	127
24	610	772	900	133.4	140

GENERAL NOTE: Dimensions are in millimeters. For inch dimensions, refer to corresponding Table I-10 in Mandatory Appendix I.

NOTES:

- (1) Hole size (where required due to bolt spacing) shall be the same as the flange bolt hole and located such that it will not interfere with bolting between two flanges.
- (2) Female ring-joint groove dimensions shall be in accordance with ASME B16.5.
- (3) The thickness of the web (or tie bar) dimension, W_t , shall be as determined by para. 4.1.

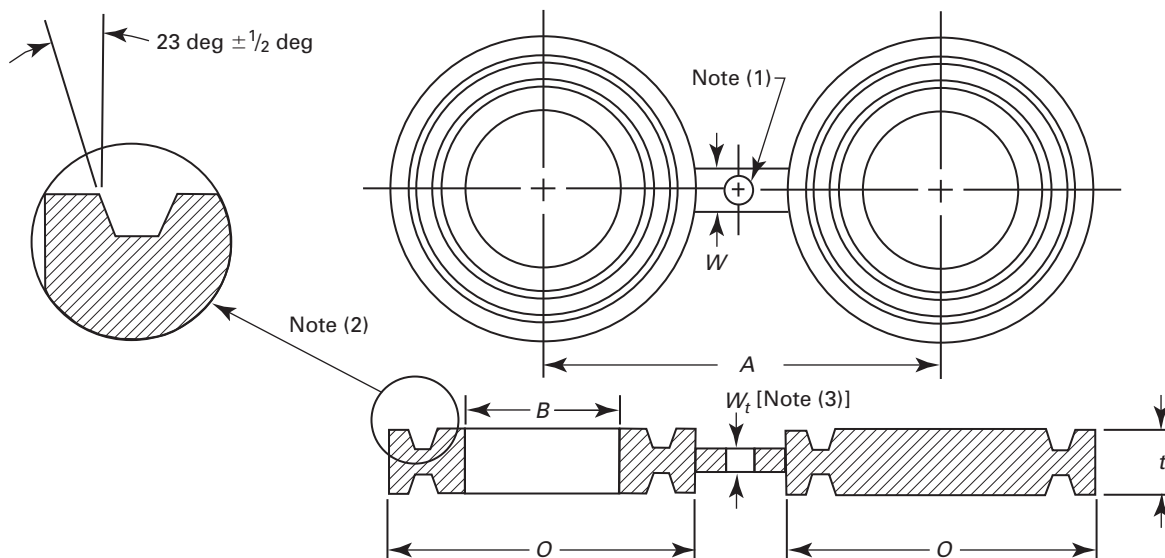
Table 11 Dimensions of Class 1500 Female Ring-Joint Facing Figure-8 Blanks

NPS	Inside Diameter, B , mm	Outside Diameter, O , mm	Centerline Dimension, A , mm	Thickness, t , mm	Web Width, W , mm
1/2	21	61	80	22.4	38
3/4	27	67	90	25.4	45
1	34	71	100	25.4	54
1 1/4	42	81	110	25.4	54
1 1/2	48	92	125	28.4	57
2	61	124	165	35.1	54
2 1/2	73	137	190	38.1	57
3	89	168	205	44.5	73
4	114	194	240	47.8	76
5	141	229	290	53.8	76
6	168	248	315	60.5	79
8	219	318	395	73.2	86
10	273	371	480	82.5	133
12	324	438	570	101.6	133
14	356	489	635	111.3	140
16	406	546	705	124.0	146
18	457	613	775	133.0	152
20	508	673	830	142.7	165
24	610	794	990	168.1	178

GENERAL NOTE: Dimensions are in millimeters. For inch dimensions, refer to corresponding Table I-11 in Mandatory Appendix I.

NOTES:

- (1) Hole size (where required due to bolt spacing) shall be the same as the flange bolt hole and located such that it will not interfere with bolting between two flanges.
- (2) Female ring-joint groove dimensions shall be in accordance with ASME B16.5.
- (3) The thickness of the web (or tie bar) dimension, W_t , shall be as determined by para. 4.1.

Table 12 Dimensions of Class 2500 Female Ring-Joint Facing Figure-8 Blanks

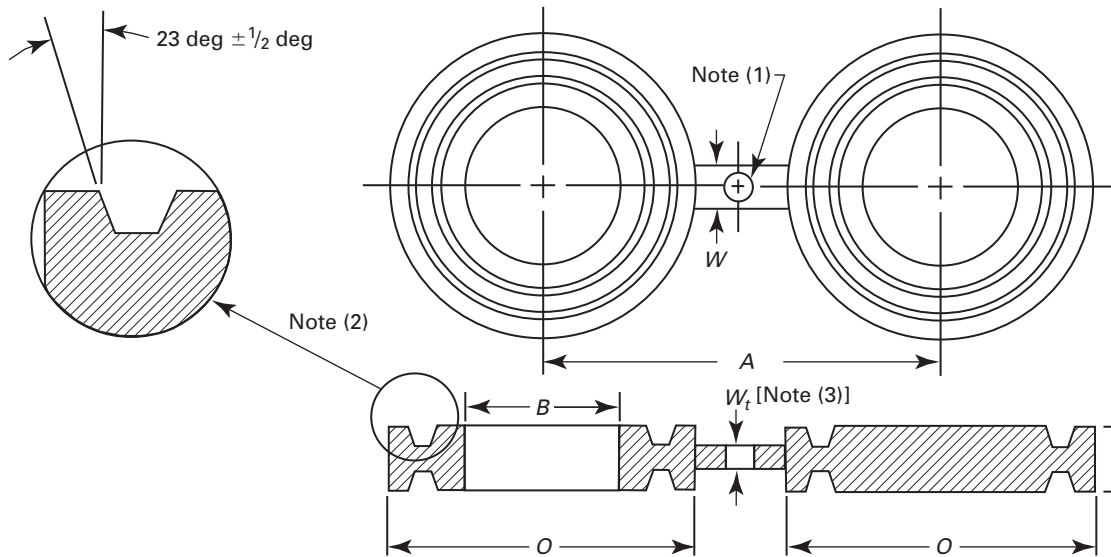

NPS	Inside Diameter, <i>B</i> , mm	Outside Diameter, <i>O</i> , mm	Centerline Dimension, <i>A</i> , mm	Thickness, <i>t</i> , mm	Web Width, <i>W</i> , mm
1/2	21	65	90	25.4	38
3/4	27	73	95	28.4	45
1	34	83	110	28.4	54
1 1/4	42	102	130	35.1	54
1 1/2	48	114	145	38.1	61
2	61	133	170	41.1	57
2 1/2	73	149	195	47.8	61
3	89	168	230	50.8	76
4	114	203	270	63.5	83
5	141	241	325	73.2	89
6	168	279	370	82.6	95
8	219	340	440	98.6	95
10	273	425	540	117.3	91
12	324	495	620	133.4	152

GENERAL NOTE: Dimensions are in millimeters. For inch dimensions, refer to corresponding Table I-12 in Mandatory Appendix I.

NOTES:

- (1) Hole size (where required due to bolt spacing) shall be the same as the flange bolt hole and located such that it will not interfere with bolting between two flanges.
- (2) Female ring-joint groove dimensions shall be in accordance with ASME B16.5.
- (3) The thickness of the web (or tie bar) dimension, W_t , shall be as determined by para. 4.1.

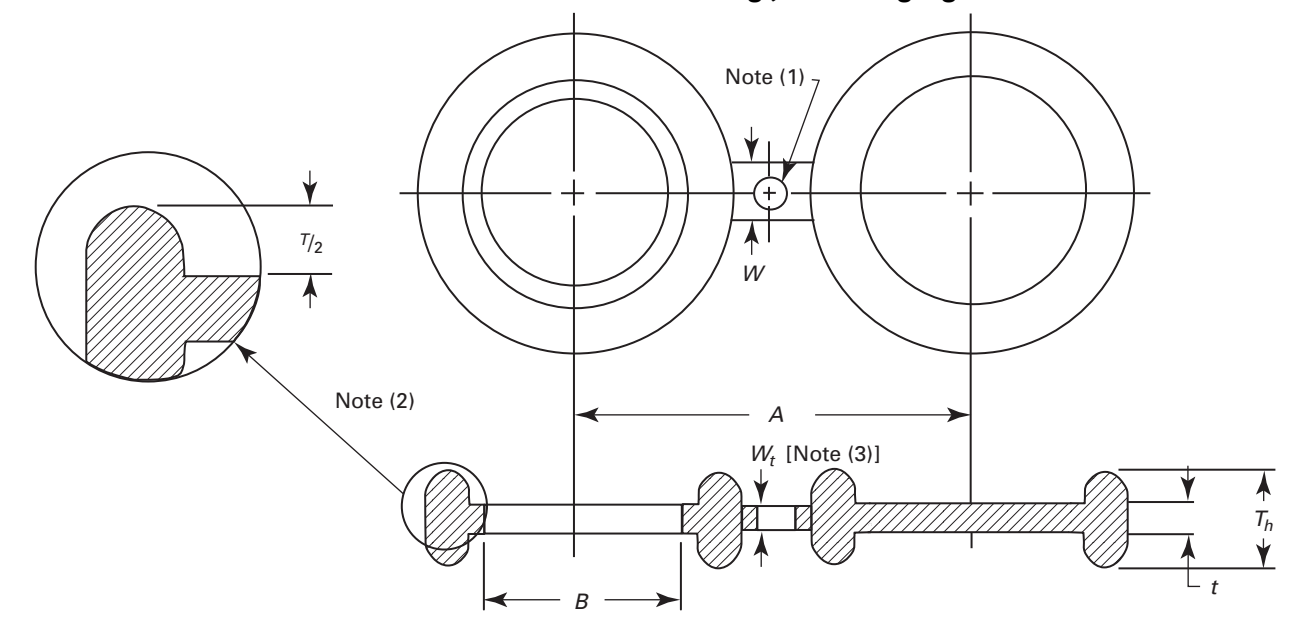
Table 13 Dimensions of Class 150 Male Ring-Joint Facing Figure-8 Blanks

NPS	Inside Diameter, B , mm	Centerline Dimension, A , mm	Thickness, t , mm	Web Width, W , mm
1	34	80	6.4	51
1 $\frac{1}{4}$	42	90	6.4	51
1 $\frac{1}{2}$	48	100	6.4	57
2	61	120	6.4	57
2 $\frac{1}{2}$	73	140	9.7	57
3	89	150	9.7	57
3 $\frac{1}{2}$	102	175	9.7	64
4	114	190	9.7	64
5	141	215	12.7	76
6	168	240	12.7	83
8	219	300	15.7	95
10	273	362	19.1	102
12	324	432	22.4	121
14	356	476	22.4	127
16	406	540	25.4	127
18	457	578	28.4	127
20	508	635	28.4	127
24	610	749	35.1	152

GENERAL NOTE: Dimensions are in millimeters. For inch dimensions, refer to corresponding Table I-13 in Mandatory Appendix I.

NOTES:

- (1) Hole size (where required due to bolt spacing) shall be the same as the flange bolt hole and located such that it will not interfere with bolting between two flanges.
- (2) Oval or octagonal ring shapes may be provided; only the oval ring is illustrated for simplicity. Ring dimensions shall be in accordance with ASME B16.20, except $T_h = T + t$, where T is the ring height specified in ASME B16.20.
- (3) The thickness of the web (or tie bar) dimension, W , shall be as determined by para. 4.1.

Table 14 Dimensions of Class 300 Male Ring-Joint Facing Figure-8 Blanks

(15)

NPS	Inside Diameter, B, mm	Centerline Dimension, A, mm	Thickness, t, mm	Web Width, W, mm
1/2	21	65	6.4	38
3/4	27	80	9.7	45
1	34	90	9.7	51
1 1/4	42	100	9.7	51
1 1/2	48	115	9.7	57
2	61	125	12.7	57
2 1/2	73	150	15.7	57
3	89	170	15.7	57
3 1/2	102	180	15.7	64
4	114	200	15.7	64
5	141	235	19.1	76
6	168	270	22.4	83
8	219	330	25.4	95
10	273	390	28.4	102
12	324	450	35.1	121
14	356	415	38.1	127
16	406	570	41.1	127
18	457	630	44.5	127
20	508	685	50.8	127
24	610	810	57.2	152

GENERAL NOTE: Dimensions are in millimeters. For inch dimensions, refer to corresponding Table I-14 in Mandatory Appendix I.

NOTES:

- (1) Hole size (where required due to bolt spacing) shall be the same as the flange bolt hole and located such that it will not interfere with bolting between two flanges.
- (2) Oval or octagonal ring shapes may be provided; only the oval ring is illustrated for simplicity. Ring dimensions shall be in accordance with ASME B16.20, except $T_h = T + t$, where T is the ring height specified in ASME B16.20.
- (3) The thickness of the web (or tie bar) dimension, W_t , shall be as determined by para. 4.1.

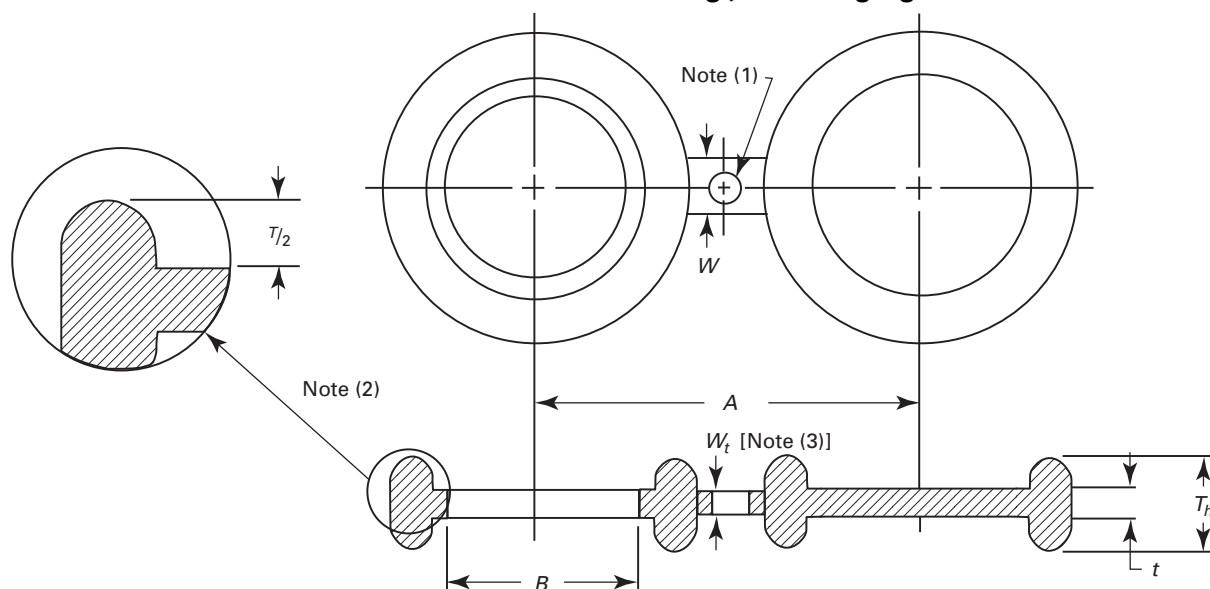
Table 15 Dimensions of Class 600 Male Ring-Joint Facing Figure-8 Blanks

NPS	Inside Diameter, B, mm	Centerline Dimension, A, mm	Thickness, t, mm	Web Width, W, mm
1/2	21	65	6.4	38
3/4	27	80	9.7	45
1	34	90	9.7	51
1 1/4	42	100	9.7	57
1 1/2	48	115	9.7	57
2	61	125	12.7	51
2 1/2	73	150	15.7	57
3	89	170	15.7	67
3 1/2	102	180	19.1	67
4	114	215	19.1	73
5	141	265	22.4	73
6	168	290	28.4	73
8	219	350	35.1	83
10	273	430	41.1	121
12	324	490	47.8	121
14	356	525	50.8	121
16	406	605	57.2	127
18	457	650	63.5	133
20	508	720	69.9	127
24	610	840	82.6	152

GENERAL NOTE: Dimensions are in millimeters. For inch dimensions, refer to corresponding Table I-15 in Mandatory Appendix I.

NOTES:

- (1) Hole size (where required due to bolt spacing) shall be the same as the flange bolt hole and located such that it will not interfere with bolting between two flanges.
- (2) Oval or octagonal ring shapes may be provided; only the oval ring is illustrated for simplicity. Ring dimensions shall be in accordance with ASME B16.20, except $T_h = T + t$, where T is the ring height specified in ASME B16.20.
- (3) The thickness of the web (or tie bar) dimension, W_t , shall be as determined by para. 4.1.

Table 16 Dimensions of Class 900 Male Ring-Joint Facing Figure-8 Blanks

NPS	Inside Diameter, B , mm	Centerline Dimension, A , mm	Thickness, t , mm	Web Width, W , mm
1/2	21	80	9.7	38
3/4	27	90	9.7	45
1	34	100	9.7	51
1 1/4	42	110	12.7	54
1 1/2	48	125	12.7	54
2	61	165	15.7	51
2 1/2	73	190	19.1	54
3	89	190	19.1	67
4	114	235	25.4	73
5	141	280	28.4	73
6	168	315	31.8	73
8	219	395	41.1	79
10	273	470	47.8	121
12	324	535	57.2	121
14	356	560	60.5	121
16	406	615	69.9	127
18	457	685	76.2	133
20	508	750	85.9	127
24	610	900	98.6	152

GENERAL NOTE: Dimensions are in millimeters. For inch dimensions, refer to corresponding Table I-16 in Mandatory Appendix I.

NOTES:

- (1) Hole size (where required due to bolt spacing) shall be the same as the flange bolt hole and located such that it will not interfere with bolting between two flanges.
- (2) Oval or octagonal ring shapes may be provided; only the oval ring is illustrated for simplicity. Ring dimensions shall be in accordance with ASME B16.20, except $T_h = T + t$, where T is the ring height specified in ASME B16.20.
- (3) The thickness of the web (or tie bar) dimension, W_t , shall be as determined by para. 4.1.

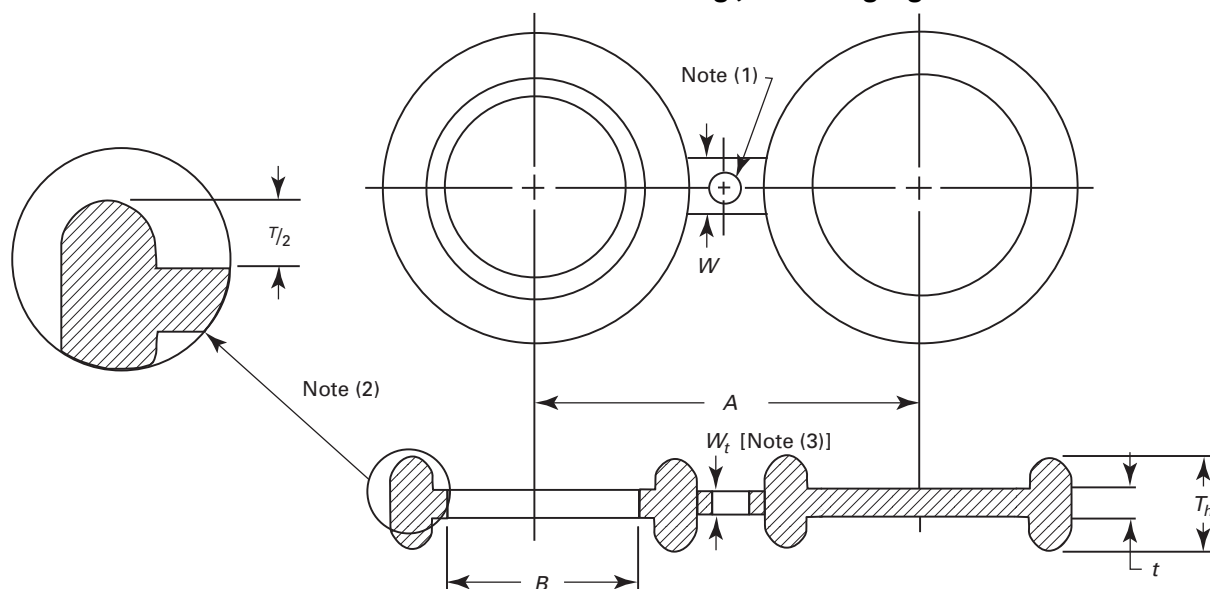
Table 17 Dimensions of Class 1500 Male Ring-Joint Facing Figure-8 Blanks

NPS	Inside Diameter, B , mm	Centerline Dimension, A , mm	Thickness, t , mm	Web Width, W , mm
1/2	21	83	9.7	38
3/4	27	89	9.7	45
1	34	102	12.7	54
1 1/4	42	111	12.7	54
1 1/2	48	124	15.7	57
2	61	165	19.1	54
2 1/2	73	191	22.4	57
3	89	203	28.4	73
4	114	241	31.8	76
5	141	292	38.1	76
6	168	318	41.1	79
8	219	394	50.8	86
10	273	483	63.5	133
12	324	572	73.2	133
14	356	635	79.2	140
16	406	705	88.9	146
18	457	775	98.6	152
20	508	832	108.0	165
24	610	991	127.0	178

GENERAL NOTE: Dimensions are in millimeters. For inch dimensions, refer to corresponding Table I-17 in Mandatory Appendix I.

NOTES:

- (1) Hole size (where required due to bolt spacing) shall be the same as the flange bolt hole and located such that it will not interfere with bolting between two flanges.
- (2) Oval or octagonal ring shapes may be provided; only the oval ring is illustrated for simplicity. Ring dimensions shall be in accordance with ASME B16.20, except $T_h = T + t$, where T is the ring height specified in ASME B16.20.
- (3) The thickness of the web (or tie bar) dimension, W_t , shall be as determined by para. 4.1.

Table 18 Dimensions of Class 2500 Male Ring-Joint Facing Figure-8 Blanks

NPS	Inside Diameter, B , mm	Centerline Dimension, A , mm	Thickness, t , mm	Web Width, W , mm
$\frac{1}{2}$	21	90	12.7	41
$\frac{3}{4}$	27	95	15.7	48
1	34	110	15.7	54
$1\frac{1}{4}$	42	130	19.1	54
$1\frac{1}{2}$	48	145	22.4	61
2	61	170	25.4	57
$2\frac{1}{2}$	73	195	28.4	61
3	89	230	31.8	76
4	114	270	38.1	83
5	141	325	47.8	89
6	168	370	57.2	95
8	219	440	69.9	95
10	273	540	82.6	95
12	324	620	98.6	152

GENERAL NOTE: Dimensions are in millimeters. For inch dimensions, refer to corresponding Table I-18 in Mandatory Appendix I.

NOTES:

- (1) Hole size (where required due to bolt spacing) shall be the same as the flange bolt hole and located such that it will not interfere with bolting between two flanges.
- (2) Oval or octagonal ring shapes may be provided; only the oval ring is illustrated for simplicity. Ring dimensions shall be in accordance with ASME B16.20, except $T_h = T + t$, where T is the ring height specified in ASME B16.20.
- (3) The thickness of the web (or tie bar) dimension, W_t , shall be as determined by para. 4.1.

INTENTIONALLY LEFT BLANK

MANDATORY APPENDIX I DIMENSIONAL DATA FOR LINE BLANKS IN U.S. CUSTOMARY UNITS

The tables and figures included in this Mandatory Appendix provide dimensional data in U.S. Customary units for the following: Class 150, 300, 600, 900, 1500, and 2500 blanks.

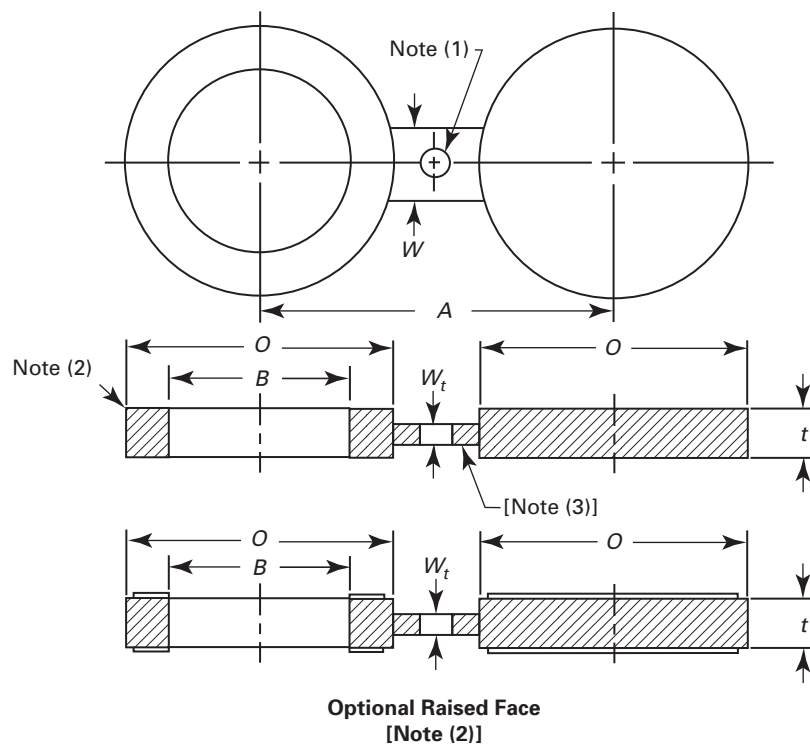
Table I-1 Dimensions of Class 150 Blanks for Use With Raised Face Flanges

NPS	Inside Diameter, <i>B</i> , in.	Outside Diameter, <i>O</i> , in.	Centerline Dimension, <i>A</i> , in.	Thickness, <i>t</i> , in.	Web Width, <i>W_t</i> , in.
1/2	0.62	1.75	2.38	0.12	1.50
3/4	0.82	2.12	2.75	0.12	1.50
1	1.05	2.50	3.12	0.12	1.50
1 1/4	1.66	2.88	3.50	0.25	1.50
1 1/2	1.90	3.25	3.88	0.25	1.50
2	2.38	4.00	4.75	0.25	2.00
2 1/2	2.88	4.75	5.50	0.25	2.00
3	3.50	5.25	6.00	0.25	2.50
3 1/2	4.00	6.25	7.00	0.38	2.50
4	4.50	6.75	7.50	0.38	2.50
5	5.56	7.62	8.50	0.38	3.00
6	6.62	8.62	9.50	0.50	3.00
8	8.62	10.88	11.75	0.50	3.00
10	10.75	13.25	14.25	0.62	4.00
12	12.75	16.00	17.00	0.75	4.00
14	14.00	17.62	18.75	0.75	4.25
16	16.00	20.12	21.25	0.88	4.25
18	18.00	21.50	22.75	1.00	4.50
20	20.00	23.75	25.00	1.12	4.75
24	24.00	28.12	29.50	1.25	5.50

GENERAL NOTE: Dimensions are in inches. For millimeter dimensions, refer to corresponding Table 1.

NOTES:

- (1) Hole size (where required due to bolt spacing) shall be the same as the flange bolt hole and located such that it will not interfere with bolting between two flanges.
- (2) Optional raised face. Refer to para. 4.3.1.
- (3) The thickness of the web (or tie bar) dimension, W_t , shall be as determined by para. 4.1.

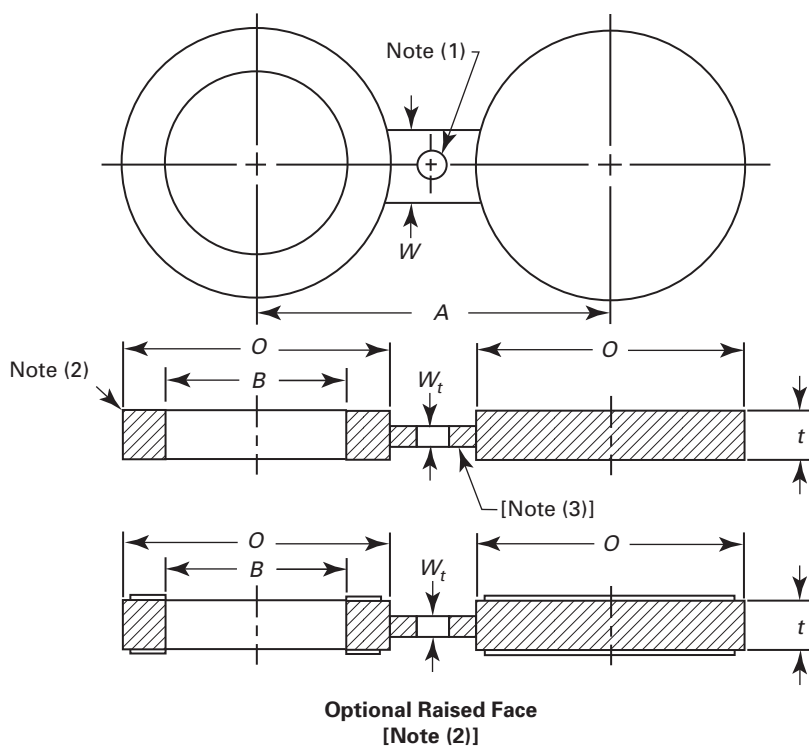
Table I-2 Dimensions of Class 300 Blanks for Use With Raised Face Flanges

NPS	Inside Diameter, <i>B</i> , in.	Outside Diameter, <i>O</i> , in.	Centerline Dimension, <i>A</i> , in.	Thickness, <i>t</i> , in.	Web Width, <i>W</i> , in.
1/2	0.62	2.00	2.62	0.25	1.50
3/4	0.82	2.50	3.25	0.25	1.50
1	1.05	2.75	3.50	0.25	1.50
1 1/4	1.66	3.12	3.88	0.25	1.50
1 1/2	1.90	3.62	4.50	0.25	1.50
2	2.38	4.25	5.00	0.38	2.00
2 1/2	2.88	5.00	5.88	0.38	2.00
3	3.50	5.75	6.62	0.38	2.50
3 1/2	4.00	6.38	7.25	0.50	2.50
4	4.50	7.00	7.88	0.50	2.50
5	5.56	8.38	9.25	0.62	3.00
6	6.62	9.75	10.62	0.62	3.00
8	8.62	12.00	13.00	0.88	3.00
10	10.75	14.12	15.25	1.00	4.00
12	12.75	16.50	17.75	1.12	4.00
14	14.00	19.00	20.25	1.25	4.25
16	16.00	21.12	22.50	1.50	4.25
18	18.00	23.38	24.75	1.62	4.50
20	20.00	25.62	27.00	1.75	4.75
24	24.00	30.38	32.00	2.00	5.50

GENERAL NOTE: Dimensions are in inches. For millimeter dimensions, refer to corresponding Table 2.

NOTES:

- (1) Hole size (where required due to bolt spacing) shall be the same as the flange bolt hole and located such that it will not interfere with bolting between two flanges.
- (2) Optional raised face. Refer to para. 4.3.1.
- (3) The thickness of the web (or tie bar) dimension, W_t , shall be as determined by para. 4.1.

Table I-3 Dimensions of Class 600 Blanks for Use With Raised Face Flanges

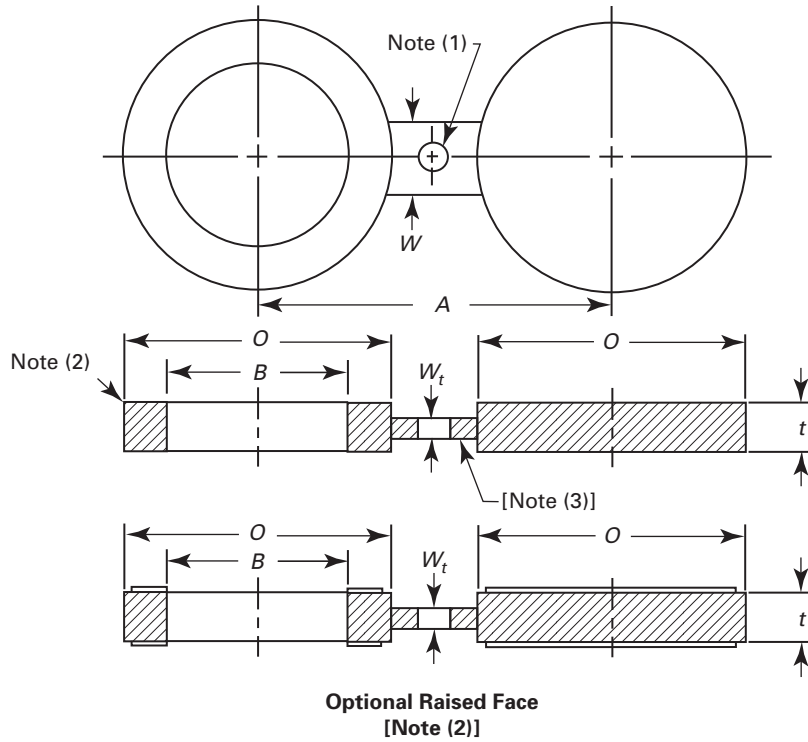

NPS	Inside Diameter, <i>B</i> , in.	Outside Diameter, <i>O</i> , in.	Centerline Dimension, <i>A</i> , in.	Thickness, <i>t</i> , in.	Web Width, <i>W</i> , in.
1/2	0.62	2.00	2.62	0.25	1.50
3/4	0.82	2.50	3.25	0.25	1.50
1	1.05	2.75	3.50	0.25	2.25
1 1/4	1.44	3.12	3.88	0.38	2.25
1 1/2	1.68	3.62	4.50	0.38	2.62
2	2.16	4.25	5.00	0.38	2.25
2 1/2	2.64	5.00	5.88	0.50	2.62
3	3.26	5.75	6.62	0.50	2.62
3 1/2	3.76	6.25	7.25	0.62	3.00
4	4.26	7.50	8.50	0.62	3.00
5	5.30	9.38	10.50	0.75	3.38
6	6.36	10.38	11.50	0.88	3.38
8	8.33	12.50	13.75	1.12	3.75
10	10.42	15.62	17.00	1.38	4.12
12	12.39	17.88	19.25	1.62	4.12
14	13.62	19.25	20.75	1.75	4.50
16	15.62	22.12	23.75	2.00	4.88
18	17.62	24.00	25.75	2.12	5.25
20	19.56	26.75	28.50	2.50	5.25
24	23.50	31.00	33.00	2.88	6.00

GENERAL NOTE: Dimensions are in inches. For millimeter dimensions, refer to corresponding Table 3.

NOTES:

- (1) Hole size (where required due to bolt spacing) shall be the same as the flange bolt hole and located such that it will not interfere with bolting between two flanges.
- (2) Optional raised face. Refer to para. 4.3.1.
- (3) The thickness of the web (or tie bar) dimension, *W_t*, shall be as determined by para. 4.1.

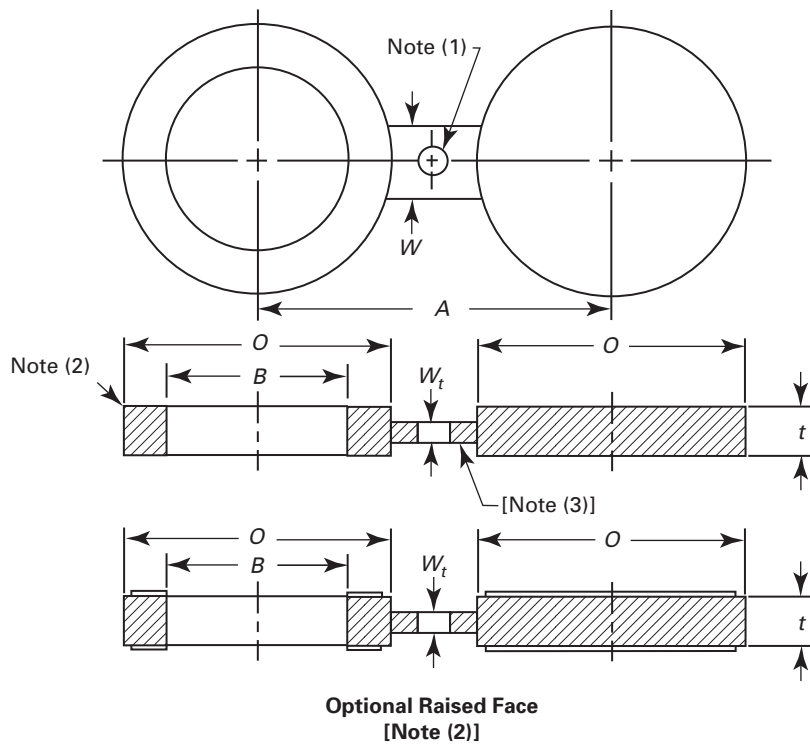
Table I-4 Dimensions of Class 900 Blanks for Use With Raised Face Flanges

NPS	Inside Diameter, <i>B</i> , in.	Outside Diameter, <i>O</i> , in.	Centerline Dimension, <i>A</i> , in.	Thickness, <i>t</i> , in.	Web Width, <i>W</i> , in.
1/2	0.62	2.38	3.25	0.25	1.50
3/4	0.82	2.62	3.50	0.25	1.62
1	1.05	3.00	4.00	0.25	2.25
1 1/4	1.44	3.38	4.38	0.38	2.25
1 1/2	1.68	3.75	4.88	0.38	2.62
2	2.16	5.50	6.50	0.50	2.25
2 1/2	2.64	6.38	7.50	0.50	2.62
3	3.26	6.50	7.50	0.62	2.62
4	4.26	8.00	9.25	0.75	3.00
5	5.30	9.62	11.00	0.88	3.38
6	6.36	11.25	12.50	1.00	3.38
8	8.33	14.00	15.50	1.38	3.75
10	10.42	17.00	18.50	1.62	4.12
12	12.39	19.50	21.00	1.88	4.12
14	13.62	20.38	22.00	2.12	4.50
16	15.62	22.50	24.25	2.38	4.88
18	17.62	25.00	27.00	2.62	5.25
20	19.56	27.38	29.50	2.88	5.25
24	23.50	32.88	35.50	3.50	6.00

GENERAL NOTE: Dimensions are in inches. For millimeter dimensions, refer to corresponding Table 4.

NOTES:

- (1) Hole size (where required due to bolt spacing) shall be the same as the flange bolt hole and located such that it will not interfere with bolting between two flanges.
- (2) Optional raised face. Refer to para. 4.3.1.
- (3) The thickness of the web (or tie bar) dimension, W_t , shall be as determined by para. 4.1.

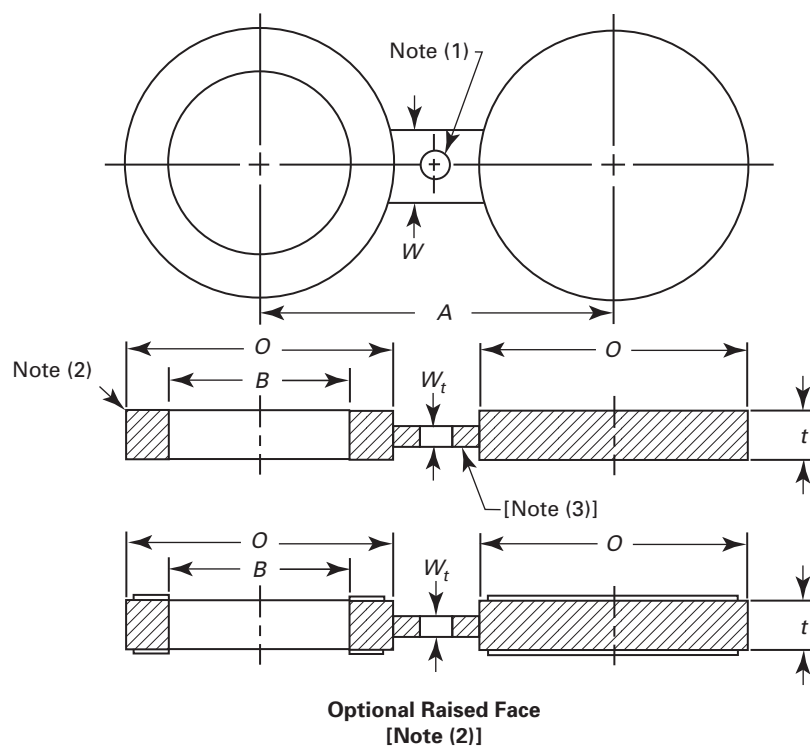
Table I-5 Dimensions of Class 1500 Blanks for Use With Raised Face Flanges

NPS	Inside Diameter, B, in.	Outside Diameter, O, in.	Centerline Dimension, A, in.	Thickness, t, in.	Web Width, W, in.
1/2	0.62	2.38	3.25	0.25	1.50
3/4	0.82	2.62	3.50	0.38	1.62
1	1.05	3.00	4.00	0.38	2.20
1 1/4	1.38	3.38	4.38	0.38	2.50
1 1/2	1.61	3.75	4.88	0.50	2.75
2	2.07	5.50	6.50	0.50	2.75
2 1/2	2.47	6.38	7.50	0.62	3.00
3	3.07	6.75	8.00	0.75	3.00
4	4.03	8.12	9.50	0.88	3.50
5	5.05	9.88	11.50	1.12	3.50
6	6.06	11.00	12.50	1.38	3.50
8	7.98	13.75	15.50	1.62	4.00
10	10.02	17.00	19.00	2.00	4.50
12	11.94	20.38	22.50	2.38	4.50
14	13.12	22.62	25.00	2.62	5.00
16	15.00	25.12	27.75	3.00	5.25
18	16.88	27.62	30.50	3.38	5.75
20	18.81	29.62	32.75	3.75	6.00
24	22.62	35.38	39.00	4.38	7.00

GENERAL NOTE: Dimensions are in inches. For millimeter dimensions, refer to corresponding Table 5.

NOTES:

- (1) Hole size (where required due to bolt spacing) shall be the same as the flange bolt hole and located such that it will not interfere with bolting between two flanges.
- (2) Optional raised face. Refer to para. 4.3.1.
- (3) The thickness of the web (or tie bar) dimension, W_t , shall be as determined by para. 4.1.

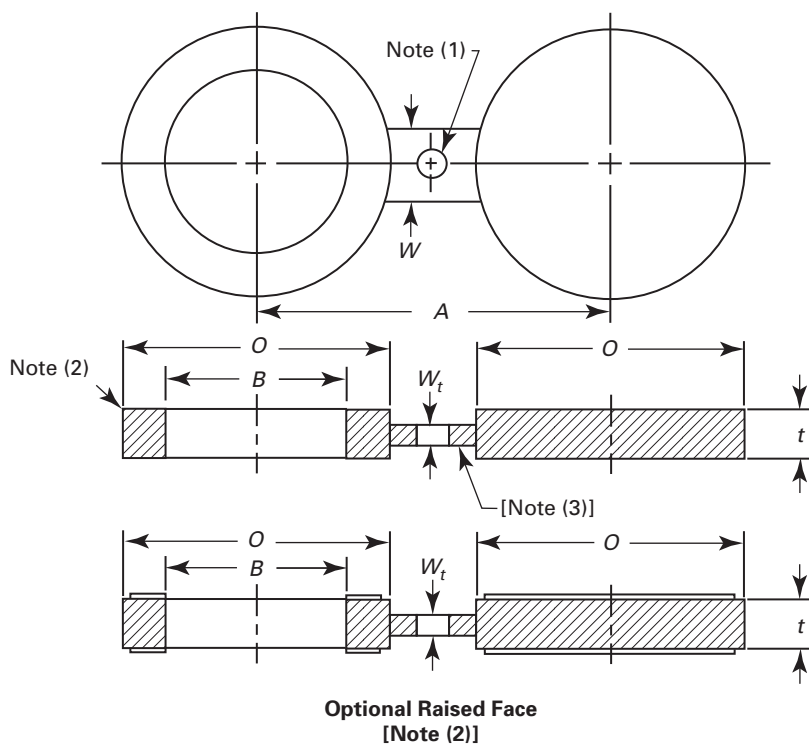
Table I-6 Dimensions of Class 2500 Blanks for Use With Raised Face Flanges

NPS	Inside Diameter, <i>B</i> , in.	Outside Diameter, <i>O</i> , in.	Centerline Dimension, <i>A</i> , in.	Thickness, <i>t</i> , in.	Web Width, <i>W</i> , in.
1/2	0.62	2.62	3.50	0.38	1.50
3/4	0.82	2.88	3.75	0.38	1.62
1	1.05	3.25	4.25	0.38	2.50
1 1/4	1.38	4.00	5.12	0.50	2.50
1 1/2	1.61	4.50	5.75	0.62	2.75
2	2.07	5.62	6.75	0.62	2.75
2 1/2	2.47	6.50	7.75	0.75	3.00
3	3.07	7.62	9.00	0.88	3.00
4	4.03	9.12	10.75	1.12	3.50
5	5.05	10.88	12.75	1.38	3.50
6	6.06	12.38	14.50	1.62	3.50
8	7.81	15.12	17.25	2.12	4.00
10	9.75	18.62	21.25	2.62	4.50
12	11.37	21.50	24.38	3.12	4.50

GENERAL NOTE: Dimensions are in inches. For millimeter dimensions, refer to corresponding Table 6.

NOTES:

- (1) Hole size (where required due to bolt spacing) shall be the same as the flange bolt hole and located such that it will not interfere with bolting between two flanges.
- (2) Optional raised face. Refer to para. 4.3.1.
- (3) The thickness of the web (or tie bar) dimension, W_t , shall be as determined by para. 4.1.

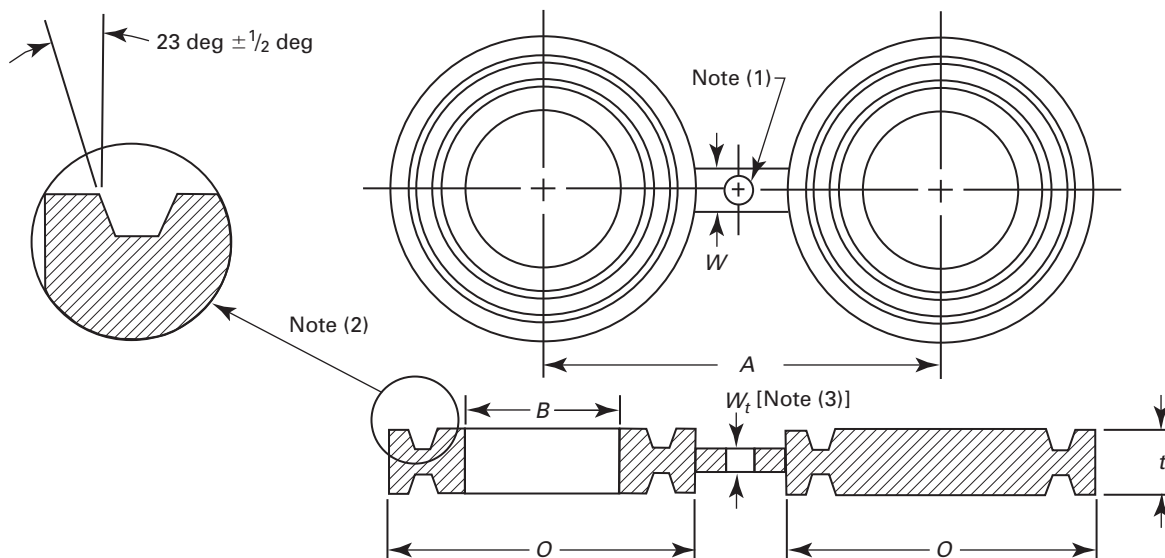
Table I-7 Dimensions of Class 150 Female Ring-Joint Facing Figure-8 Blanks

NPS	Inside Diameter, B , in.	Outside Diameter, O , in.	Centerline Dimension, A , in.	Thickness, t , in.	Web Width, W , in.
1	1.32	2.50	3.12	0.75	2.00
1 $\frac{1}{4}$	1.66	2.88	3.50	0.75	2.00
1 $\frac{1}{2}$	1.90	3.25	3.88	0.75	2.25
2	2.38	4.00	4.75	0.75	2.25
2 $\frac{1}{2}$	2.88	4.75	5.50	0.88	2.25
3	3.50	5.25	6.00	0.88	2.25
3 $\frac{1}{2}$	4.00	6.06	7.00	0.88	2.50
4	4.50	6.75	7.50	0.88	2.50
5	5.56	7.62	8.50	1.00	2.75
6	6.62	8.62	9.50	1.00	3.25
8	8.62	10.75	11.75	1.12	3.75
10	10.75	13.00	14.25	1.25	4.00
12	12.75	16.00	17.00	1.38	4.75
14	14.00	16.75	18.75	1.38	5.00
16	16.00	19.00	21.25	1.50	5.00
18	18.00	21.50	22.75	1.62	5.00
20	20.00	23.50	25.00	1.62	5.00
24	24.00	28.00	29.50	1.88	6.00

GENERAL NOTE: Dimensions are in inches. For millimeter dimensions, refer to corresponding Table 7.

NOTES:

- (1) Hole size (where required due to bolt spacing) shall be the same as the flange bolt hole and located such that it will not interfere with bolting between two flanges.
- (2) Female ring-joint groove dimensions shall be in accordance with ASME B16.5.
- (3) The thickness of the web (or tie bar) dimension, W_t , shall be as determined by para. 4.1.

Table I-8 Dimensions of Class 300 Female Ring-Joint Facing Figure-8 Blanks

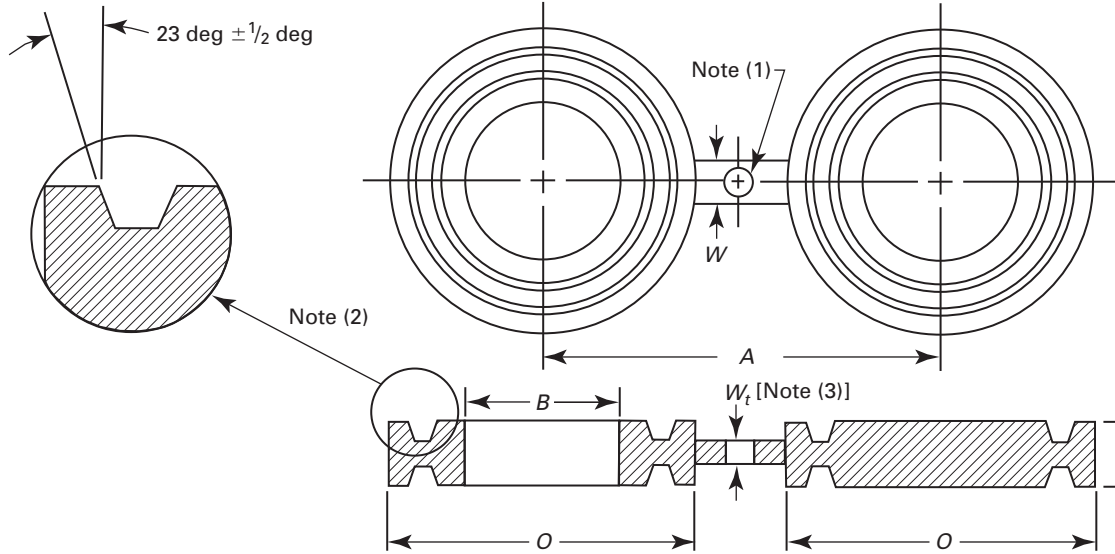

NPS	Inside Diameter, <i>B</i> , in.	Outside Diameter, <i>O</i> , in.	Centerline Dimension, <i>A</i> , in.	Thickness, <i>t</i> , in.	Web Width, <i>W</i> , in.
1/2	0.84	2.00	2.62	0.62	1.50
3/4	1.05	2.50	3.25	0.75	1.75
1	1.32	2.75	3.50	0.75	2.00
1 1/4	1.66	3.12	3.88	0.88	2.00
1 1/2	1.90	3.56	4.50	0.88	2.25
2	2.38	4.25	5.00	1.00	2.25
2 1/2	2.88	5.00	5.88	1.12	2.25
3	3.50	5.75	6.62	1.12	2.25
3 1/2	4.00	6.25	7.25	1.12	2.50
4	4.50	6.88	7.88	1.25	2.50
5	5.56	8.25	9.25	1.38	2.75
6	6.62	9.50	10.62	1.38	3.25
8	8.62	11.88	13.00	1.62	3.75
10	10.75	14.00	15.25	1.75	4.00
12	12.75	16.25	17.75	2.00	4.75
14	14.00	18.00	20.25	2.12	5.00
16	16.00	20.00	22.50	2.25	5.00
18	18.00	22.62	24.75	2.38	5.00
20	20.00	25.00	27.00	2.75	5.00
24	24.00	29.50	32.00	3.12	6.00

GENERAL NOTE: Dimensions are in inches. For millimeter dimensions, refer to corresponding Table 8.

NOTES:

- (1) Hole size (where required due to bolt spacing) shall be the same as the flange bolt hole and located such that it will not interfere with bolting between two flanges.
- (2) Female ring-joint groove dimensions shall be in accordance with ASME B16.5.
- (3) The thickness of the web (or tie bar) dimension, W_t , shall be as determined by para. 4.1.

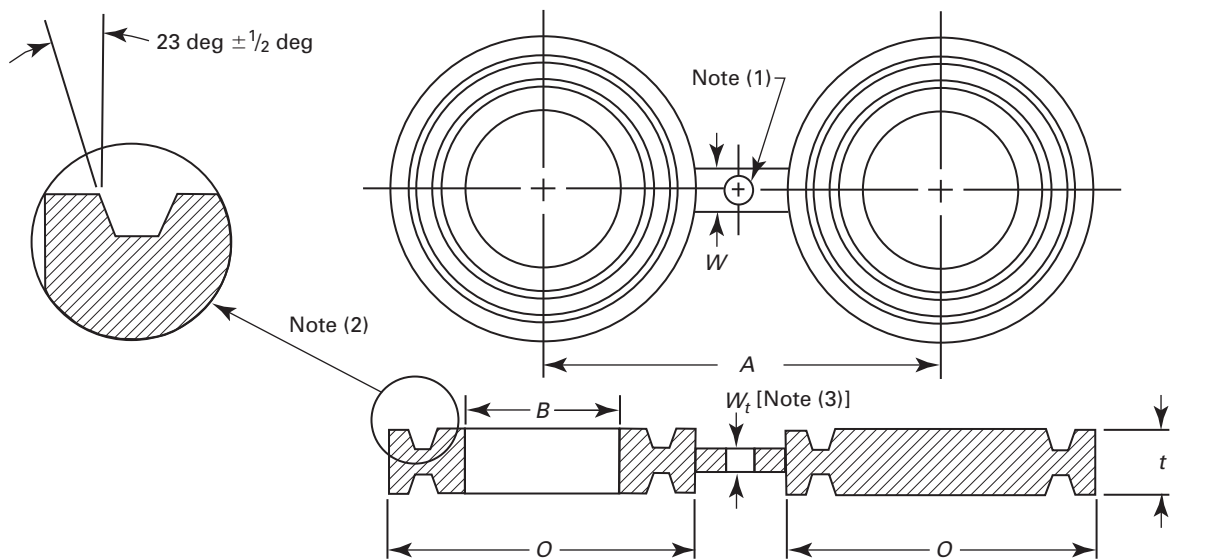
Table I-9 Dimensions of Class 600 Female Ring-Joint Facing Figure-8 Blanks

NPS	Inside Diameter, B , in.	Outside Diameter, O , in.	Centerline Dimension, A , in.	Thickness, t , in.	Web Width, W , in.
1/2	0.84	2.00	2.62	0.75	1.50
3/4	1.05	2.50	3.25	0.88	1.75
1	1.32	2.75	3.50	0.88	2.00
1 1/4	1.66	3.12	3.88	0.88	2.00
1 1/2	1.90	3.56	4.50	0.88	2.25
2	2.38	4.25	5.00	1.12	2.25
2 1/2	2.88	5.00	5.88	1.25	2.25
3	3.50	5.75	6.62	1.25	2.25
3 1/2	4.00	6.25	7.25	1.38	2.50
4	4.50	6.88	8.50	1.38	2.50
5	5.56	8.25	10.50	1.50	2.75
6	6.62	9.50	11.50	1.75	3.25
8	8.62	11.88	13.75	2.00	3.75
10	10.75	14.00	17.00	2.25	4.00
12	12.75	16.25	19.25	2.50	4.75
14	14.00	18.00	20.75	2.62	5.00
16	16.00	20.00	23.75	2.88	5.00
18	18.00	22.62	25.75	3.12	5.00
20	20.00	25.00	28.50	3.50	5.00
24	24.00	29.50	33.00	4.12	6.00

GENERAL NOTE: Dimensions are in inches. For millimeter dimensions, refer to corresponding Table 9.

NOTES:

- (1) Hole size (where required due to bolt spacing) shall be the same as the flange bolt hole and located such that it will not interfere with bolting between two flanges.
- (2) Female ring-joint groove dimensions shall be in accordance with ASME B16.5.
- (3) The thickness of the web (or tie bar) dimension, W_t , shall be as determined by para. 4.1.

Table I-10 Dimensions of Class 900 Female Ring-Joint Facing Figure-8 Blanks

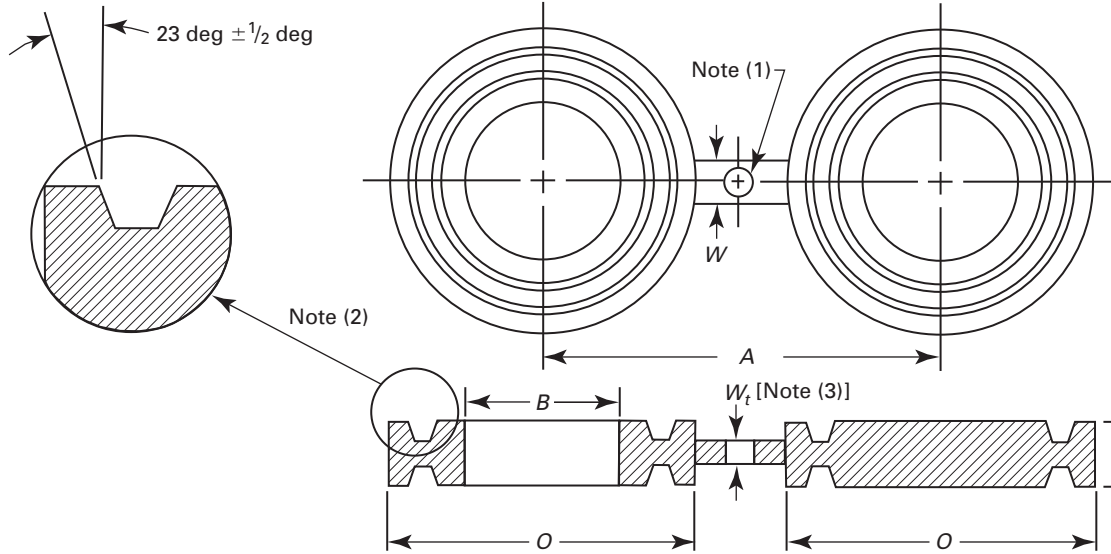

NPS	Inside Diameter, <i>B</i> , in.	Outside Diameter, <i>O</i> , in.	Centerline Dimension, <i>A</i> , in.	Thickness, <i>t</i> , in.	Web Width, <i>W</i> , in.
1/2	0.84	2.38	3.25	0.88	1.50
3/4	1.05	2.62	3.50	0.88	1.75
1	1.32	2.81	4.00	0.88	2.00
1 1/4	1.66	3.19	4.38	1.00	2.00
1 1/2	1.90	3.62	4.88	1.00	2.50
2	2.38	4.88	6.50	1.25	2.00
2 1/2	2.88	5.38	7.50	1.38	2.62
3	3.50	6.12	7.50	1.38	2.62
4	4.50	7.12	9.25	1.62	2.88
5	5.56	8.50	11.00	1.75	2.88
6	6.62	9.50	12.50	1.88	2.88
8	8.62	12.12	15.50	2.25	3.12
10	10.75	14.25	18.50	2.50	4.75
12	12.75	16.50	21.00	2.88	4.75
14	14.00	18.38	22.00	3.25	4.75
16	16.00	20.62	24.25	3.62	5.00
18	18.00	23.38	27.00	4.00	5.25
20	20.00	25.50	29.50	4.38	5.00
24	24.00	30.38	35.50	5.25	5.50

GENERAL NOTE: Dimensions are in inches. For millimeter dimensions, refer to corresponding Table 10.

NOTES:

- (1) Hole size (where required due to bolt spacing) shall be the same as the flange bolt hole and located such that it will not interfere with bolting between two flanges.
- (2) Female ring-joint groove dimensions shall be in accordance with ASME B16.5.
- (3) The thickness of the web (or tie bar) dimension, *W_t*, shall be as determined by para. 4.1.

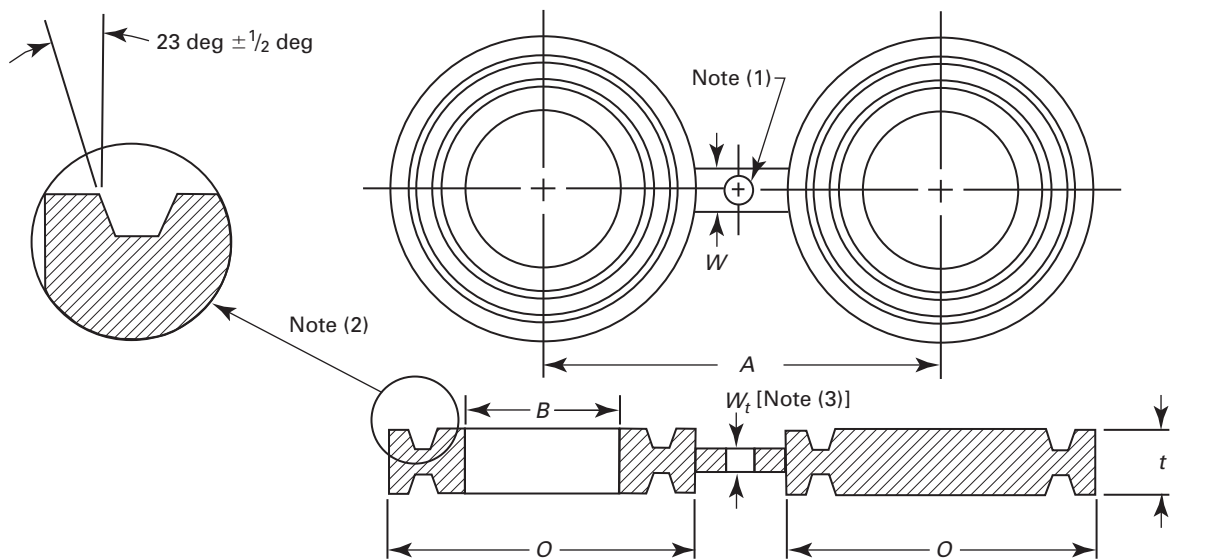
Table I-11 Dimensions of Class 1500 Female Ring-Joint Facing Figure-8 Blanks

NPS	Inside Diameter, B , in.	Outside Diameter, O , in.	Centerline Dimension, A , in.	Thickness, t , in.	Web Width, W , in.
1/2	0.84	2.38	3.25	0.88	1.50
3/4	1.05	2.62	3.50	1.00	1.75
1	1.32	2.81	4.00	1.00	2.12
1 1/4	1.66	3.19	4.38	1.00	2.12
1 1/2	1.90	3.62	4.88	1.12	2.25
2	2.38	4.88	6.50	1.38	2.12
2 1/2	2.88	5.38	7.50	1.50	2.25
3	3.50	6.62	8.00	1.75	2.88
4	4.50	7.62	9.50	1.88	3.00
5	5.56	9.00	11.50	2.12	3.00
6	6.62	9.75	12.50	2.38	3.12
8	8.62	12.50	15.50	2.88	3.38
10	10.75	14.62	19.00	3.25	5.25
12	12.75	17.25	22.50	4.00	5.25
14	14.00	19.25	25.00	4.38	5.50
16	16.00	21.50	27.75	4.88	5.75
18	18.00	24.12	30.50	5.25	6.00
20	20.00	26.50	32.75	5.62	6.50
24	24.00	31.25	39.00	6.62	7.00

GENERAL NOTE: Dimensions are in inches. For millimeter dimensions, refer to corresponding Table 11.

NOTES:

- (1) Hole size (where required due to bolt spacing) shall be the same as the flange bolt hole and located such that it will not interfere with bolting between two flanges.
- (2) Female ring-joint groove dimensions shall be in accordance with ASME B16.5.
- (3) The thickness of the web (or tie bar) dimension, W_t , shall be as determined by para. 4.1.

Table I-12 Dimensions of Class 2500 Female Ring-Joint Facing Figure-8 Blanks

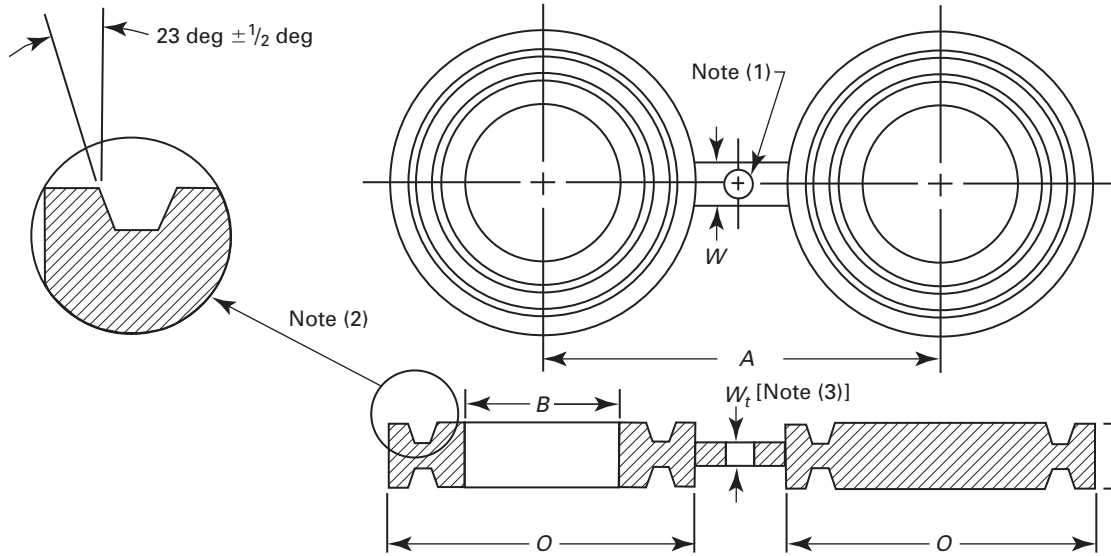

NPS	Inside Diameter, <i>B</i> , in.	Outside Diameter, <i>O</i> , in.	Centerline Dimension, <i>A</i> , in.	Thickness, <i>t</i> , in.	Web Width, <i>W</i> , in.
1/2	0.84	2.56	3.50	1.00	1.50
3/4	1.05	2.88	3.75	1.12	1.75
1	1.32	3.25	4.25	1.12	2.12
1 1/4	1.66	4.00	5.12	1.38	2.12
1 1/2	1.90	4.50	5.75	1.50	2.38
2	2.38	5.25	6.75	1.62	2.25
2 1/2	2.88	5.88	7.75	1.88	2.38
3	3.50	6.62	9.00	2.00	3.00
4	4.50	8.00	10.75	2.50	3.25
5	5.56	9.50	12.75	2.88	3.50
6	6.62	11.00	14.50	3.25	3.75
8	8.62	13.38	17.25	3.88	3.75
10	10.75	16.75	21.25	4.62	3.58
12	12.75	19.50	24.38	5.25	6.00

GENERAL NOTE: Dimensions are in inches. For millimeter dimensions, refer to corresponding Table 12.

NOTES:

- (1) Hole size (where required due to bolt spacing) shall be the same as the flange bolt hole and located such that it will not interfere with bolting between two flanges.
- (2) Female ring-joint groove dimensions shall be in accordance with ASME B16.5.
- (3) The thickness of the web (or tie bar) dimension, W_t , shall be as determined by para. 4.1.

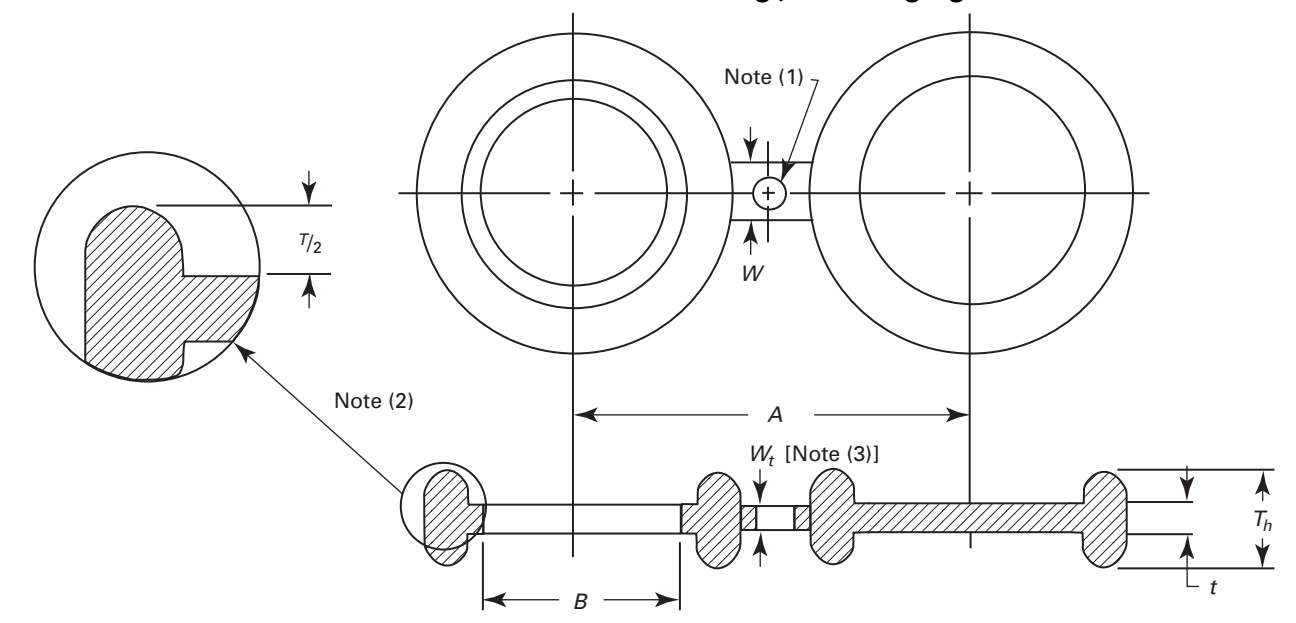
Table I-13 Dimensions of Class 150 Male Ring-Joint Facing Figure-8 Blanks

NPS	Inside Diameter, B , in.	Centerline Dimension, A , in.	Thickness, t , in.	Web Width, W , in.
1	1.32	3.12	0.25	2.00
1 $\frac{1}{4}$	1.66	3.50	0.25	2.00
1 $\frac{1}{2}$	1.90	3.88	0.25	2.25
2	2.38	4.75	0.25	2.25
2 $\frac{1}{2}$	2.88	5.50	0.38	2.25
3	3.50	6.00	0.38	2.25
3 $\frac{1}{2}$	4.00	7.00	0.38	2.50
4	4.50	7.50	0.38	2.50
5	5.56	8.50	0.50	3.00
6	6.62	9.50	0.50	3.25
8	8.62	11.75	0.62	3.75
10	10.75	14.25	0.75	4.00
12	12.75	17.00	0.88	4.75
14	14.00	18.75	0.88	5.00
16	16.00	21.25	1.00	5.00
18	18.00	22.75	1.12	5.00
20	20.00	25.00	1.12	5.00
24	24.00	29.50	1.38	6.00

GENERAL NOTE: Dimensions are in inches. For millimeter dimensions, refer to corresponding Table 13.

NOTES:

- (1) Hole size (where required due to bolt spacing) shall be the same as the flange bolt hole and located such that it will not interfere with bolting between two flanges.
- (2) Oval or octagonal ring shapes may be provided; only the oval ring is illustrated for simplicity. Ring dimensions shall be in accordance with ASME B16.20, except $T_h = T + t$, where T is the ring height specified in ASME B16.20.
- (3) The thickness of the web (or tie bar) dimension, W_t , shall be as determined by para. 4.1.

Table I-14 Dimensions of Class 300 Male Ring-Joint Facing Figure-8 Blanks

(15)

NPS	Inside Diameter, B, in.	Centerline Dimension, A, in.	Thickness, t, in.	Web Width, W, in.
1/2	0.84	2.62	0.25	1.50
3/4	1.05	3.25	0.38	1.75
1	1.32	3.50	0.38	2.00
1 1/4	1.66	3.88	0.38	2.00
1 1/2	1.90	4.50	0.38	2.25
2	2.38	5.00	0.50	2.25
2 1/2	2.88	5.88	0.62	2.25
3	3.50	6.62	0.62	2.25
3 1/2	4.00	7.25	0.62	2.50
4	4.50	7.88	0.62	2.50
5	5.56	9.25	0.75	3.00
6	6.62	10.62	0.88	3.25
8	8.62	13.00	1.00	3.75
10	10.75	15.25	1.12	4.00
12	12.75	17.75	1.38	4.75
14	14.00	20.25	1.50	5.00
16	16.00	22.50	1.62	5.00
18	18.00	24.75	1.75	5.00
20	20.00	27.00	2.00	5.00
24	24.00	32.00	2.25	6.00

GENERAL NOTE: Dimensions are in inches. For millimeter dimensions, refer to corresponding Table 14.

NOTES:

- (1) Hole size (where required due to bolt spacing) shall be the same as the flange bolt hole and located such that it will not interfere with bolting between two flanges.
- (2) Oval or octagonal ring shapes may be provided; only the oval ring is illustrated for simplicity. Ring dimensions shall be in accordance with ASME B16.20, except $T_h = T + t$, where T is the ring height specified in ASME B16.20.
- (3) The thickness of the web (or tie bar) dimension, W_t , shall be as determined by para. 4.1.

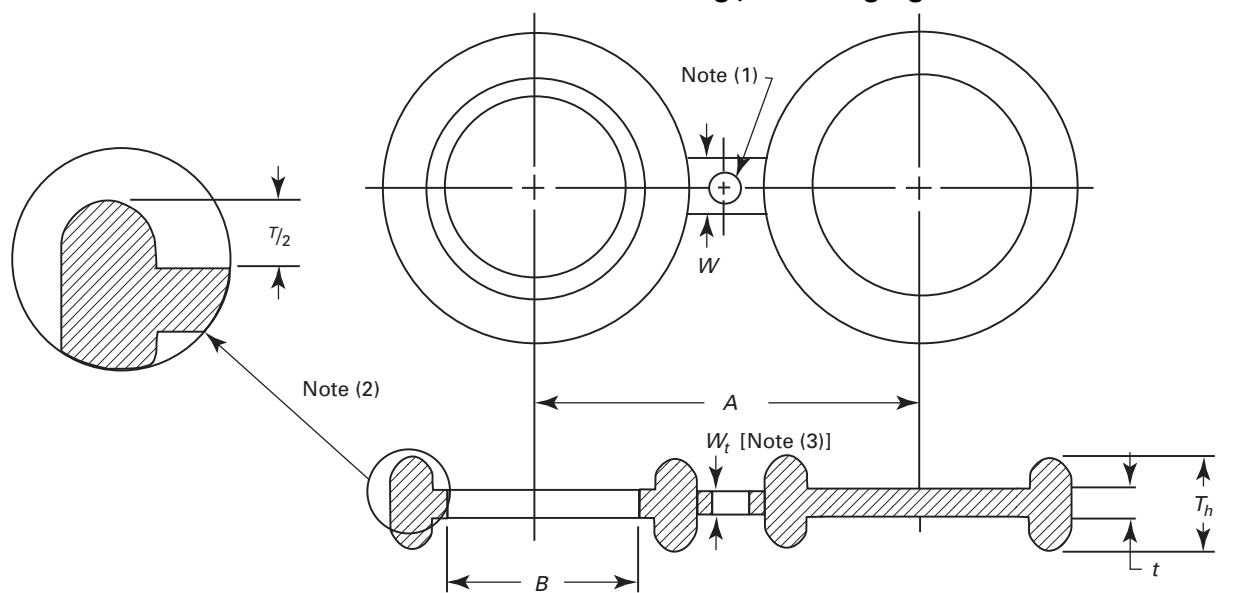
Table I-15 Dimensions of Class 600 Male Ring-Joint Facing Figure-8 Blanks

NPS	Inside Diameter, B, in.	Centerline Dimension, A, in.	Thickness, t, in.	Web Width, W, in.
1/2	0.84	2.62	0.25	1.50
3/4	1.05	3.25	0.38	1.75
1	1.32	3.50	0.38	2.00
1 1/4	1.66	3.88	0.38	2.25
1 1/2	1.90	4.50	0.38	2.25
2	2.38	5.00	0.50	2.00
2 1/2	2.88	5.88	0.62	2.25
3	3.50	6.62	0.62	2.62
3 1/2	4.00	7.25	0.75	2.62
4	4.50	8.50	0.75	2.88
5	5.56	10.50	0.88	2.88
6	6.62	11.50	1.12	2.88
8	8.62	13.75	1.38	3.25
10	10.75	17.00	1.62	4.75
12	12.75	19.25	1.88	4.75
14	14.00	20.75	2.00	4.75
16	16.00	23.75	2.25	5.00
18	18.00	25.75	2.50	5.25
20	20.00	28.50	2.75	5.00
24	24.00	33.00	3.25	6.00

GENERAL NOTE: Dimensions are in inches. For millimeter dimensions, refer to corresponding Table 15.

NOTES:

- (1) Hole size (where required due to bolt spacing) shall be the same as the flange bolt hole and located such that it will not interfere with bolting between two flanges.
- (2) Oval or octagonal ring shapes may be provided; only the oval ring is illustrated for simplicity. Ring dimensions shall be in accordance with ASME B16.20, except $T_h = T + t$, where T is the ring height specified in ASME B16.20.
- (3) The thickness of the web (or tie bar) dimension, W_t , shall be as determined by para. 4.1.

Table I-16 Dimensions of Class 900 Male Ring-Joint Facing Figure-8 Blanks

NPS	Inside Diameter, B , in.	Centerline Dimension, A , in.	Thickness, t , in.	Web Width, W , in.
1/2	0.84	3.25	0.38	1.50
3/4	1.05	3.50	0.38	1.75
1	1.32	4.00	0.38	2.00
1 1/4	1.66	4.38	0.50	2.12
1 1/2	1.90	4.88	0.50	2.12
2	2.38	6.50	0.62	2.00
2 1/2	2.88	7.50	0.75	2.12
3	3.50	7.50	0.75	2.62
4	4.50	9.25	1.00	2.88
5	5.56	11.00	1.12	2.88
6	6.62	12.50	1.25	2.88
8	8.62	15.50	1.62	3.12
10	10.75	18.50	1.88	4.75
12	12.75	21.00	2.25	4.75
14	14.00	22.00	2.38	4.75
16	16.00	24.25	2.75	5.00
18	18.00	27.00	3.00	5.25
20	20.00	29.50	3.38	5.00
24	24.00	35.50	3.88	6.00

GENERAL NOTE: Dimensions are in inches. For millimeter dimensions, refer to corresponding Table 16.

NOTES:

- (1) Hole size (where required due to bolt spacing) shall be the same as the flange bolt hole and located such that it will not interfere with bolting between two flanges.
- (2) Oval or octagonal ring shapes may be provided; only the oval ring is illustrated for simplicity. Ring dimensions shall be in accordance with ASME B16.20, except $T_h = T + t$, where T is the ring height specified in ASME B16.20.
- (3) The thickness of the web (or tie bar) dimension, W_t , shall be as determined by para. 4.1.

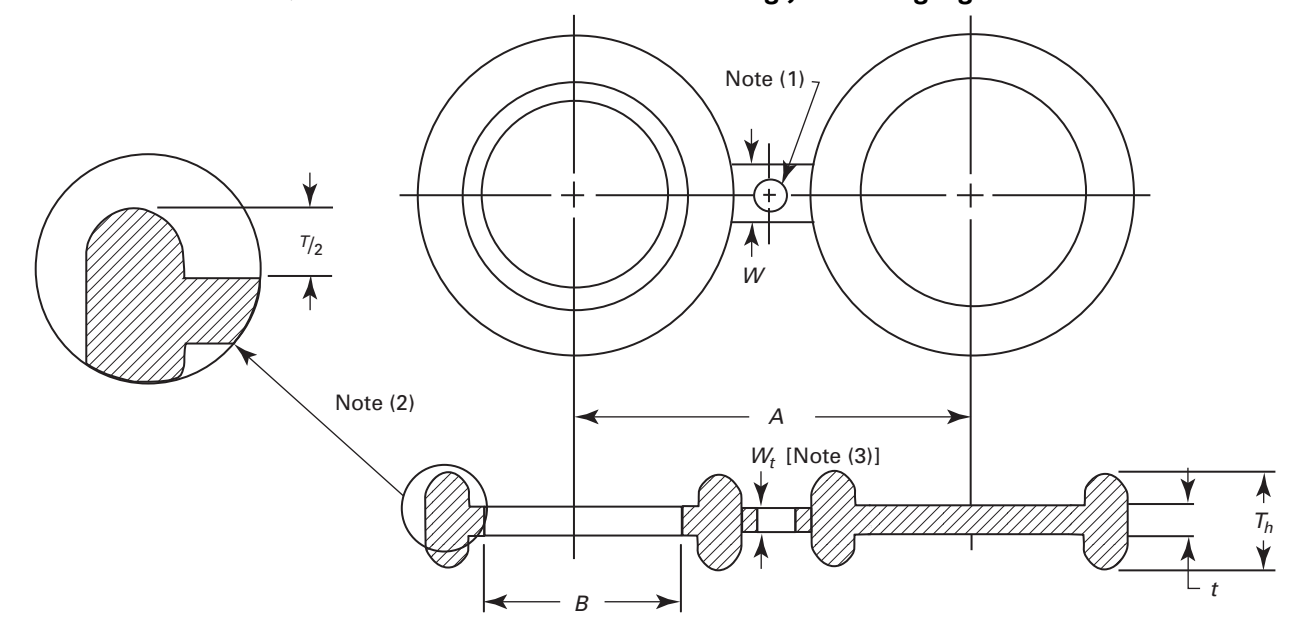
Table I-17 Dimensions of Class 1500 Male Ring-Joint Facing Figure-8 Blanks

NPS	Inside Diameter, B , in.	Centerline Dimension, A , in.	Thickness, t , in.	Web Width, W , in.
1/2	0.84	3.25	0.38	1.50
3/4	1.05	3.50	0.38	1.75
1	1.32	4.00	0.50	2.12
1 1/4	1.66	4.38	0.50	2.12
1 1/2	1.90	4.88	0.62	2.25
2	2.38	6.50	0.75	2.12
2 1/2	2.88	7.50	0.88	2.25
3	3.50	8.00	1.12	2.88
4	4.50	9.50	1.25	3.00
5	5.56	11.50	1.50	3.00
6	6.62	12.50	1.62	3.12
8	8.62	15.50	2.00	3.38
10	10.75	19.00	2.50	5.25
12	12.75	22.50	2.88	5.25
14	14.00	25.00	3.12	5.50
16	16.00	27.75	3.50	5.75
18	18.00	30.50	3.88	6.00
20	20.00	32.75	4.25	6.50
24	24.00	39.00	5.00	7.00

GENERAL NOTE: Dimensions are in inches. For millimeter dimensions, refer to corresponding Table 17.

NOTES:

- (1) Hole size (where required due to bolt spacing) shall be the same as the flange bolt hole and located such that it will not interfere with bolting between two flanges.
- (2) Oval or octagonal ring shapes may be provided; only the oval ring is illustrated for simplicity. Ring dimensions shall be in accordance with ASME B16.20, except $T_h = T + t$, where T is the ring height specified in ASME B16.20.
- (3) The thickness of the web (or tie bar) dimension, W_t , shall be as determined by para. 4.1.

Table I-18 Dimensions of Class 2500 Male Ring-Joint Facing Figure-8 Blanks

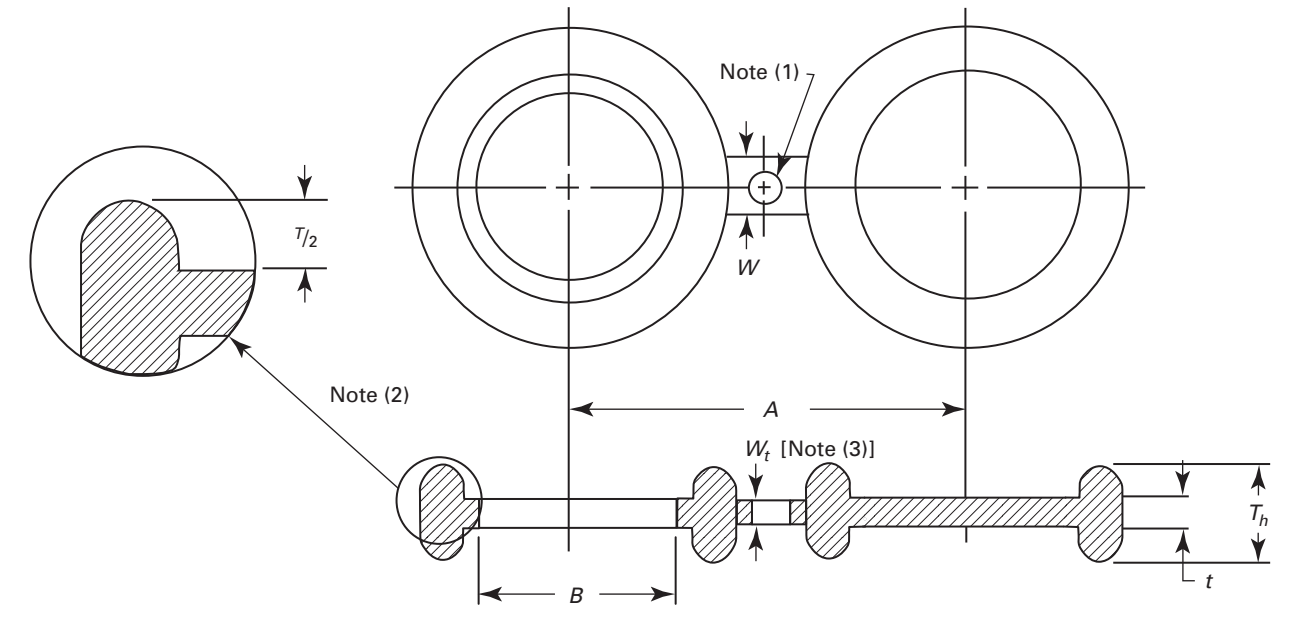

NPS	Inside Diameter, B, in.	Centerline Dimension, A, in.	Thickness, t, in.	Web Width, W, in.
1/2	0.84	3.50	0.50	1.62
3/4	1.05	3.75	0.62	1.88
1	1.32	4.25	0.62	2.12
1 1/4	1.66	5.12	0.75	2.12
1 1/2	1.90	5.75	0.88	2.38
2	2.38	6.75	1.00	2.25
2 1/2	2.88	7.75	1.12	2.38
3	3.50	9.00	1.25	3.00
4	4.50	10.75	1.50	3.25
5	5.56	12.75	1.88	3.50
6	6.62	14.50	2.25	3.75
8	8.62	17.25	2.75	3.75
10	10.75	21.25	3.25	3.75
12	12.75	24.38	3.88	6.00

GENERAL NOTE: Dimensions are in inches. For millimeter dimensions, refer to corresponding Table 18.

NOTES:

- (1) Hole size (where required due to bolt spacing) shall be the same as the flange bolt hole and located such that it will not interfere with bolting between two flanges.
- (2) Oval or octagonal ring shapes may be provided; only the oval ring is illustrated for simplicity. Ring dimensions shall be in accordance with ASME B16.20, except $T_h = T + t$, where T is the ring height specified in ASME B16.20.
- (3) The thickness of the web (or tie bar) dimension, W_b , shall be as determined by para. 4.1.

MANDATORY APPENDIX II REFERENCES

The following is a list of publications referenced in this Standard. The latest editions of ASME publications are to be used.

ASME B16.5, Pipe Flanges and Flanged Fittings

ASME B16.20, Metallic Gaskets for Pipe Flanges — Ring-Joint, Spiral-Wound, and Jacketed

ASME B46.1, Surface Texture (Surface Roughness, Waviness, and Lay)

Publisher: The American Society of Mechanical Engineers (ASME), Two Park Avenue, New York, NY 10016-5990 (www.asme.org)

ASTM E29-13, Standard Practice for Using Significant Digits in Test Data to Determine Conformance with Specifications¹

¹ May also be obtained from the American National Standards Institute (ANSI), 25 West 43rd Street, New York, NY 10036.

Publisher: American Society for Testing and Materials (ASTM International), 100 Barr Harbor Drive, West Conshohocken, PA 19428-2959 (www.astm.org)

ISO 6708:1995, Pipework components — Definition and selection of DN (nominal size)¹

ISO 9000:2005, Quality management systems — Fundamentals and vocabulary¹

ISO 9001:2008, Quality management systems — Requirements¹

ISO 9004:2000, Quality management systems — Guidelines for performance improvements¹

Publisher: International Organization for Standardization (ISO) Central Secretariat, Chemin de Blandonnet 8, Case postale 401, 1214 Vernier, Geneva, Switzerland (www.iso.org)

NONMANDATORY APPENDIX A QUALITY SYSTEM PROGRAM

The products manufactured in accordance with this Standard shall be produced under a quality system program following the principles of an appropriate standard from the ISO 9000 series.¹ A determination of the need for registration and/or certification of the product

¹ The series is also available from the American National Standards Institute (ANSI) and the American Society for Quality (ASQ) as American National Standards that are identified by the prefix "Q," replacing the prefix "ISO." Each standard of the series is listed in Mandatory Appendix II.

manufacturer's quality system program by an independent organization shall be the responsibility of the manufacturer. The detailed documentation demonstrating program compliance shall be available to the purchaser at the manufacturer's facility. A written summary description of the program utilized by the product manufacturer shall be available to the purchaser upon request. The product manufacturer is defined as the entity whose name or trademark appears on the product in accordance with the marking or identification requirements of this Standard.

INTENTIONALLY LEFT BLANK

ASME B16.48-2015

ISBN 978-0-7918-7053-2



9 780791 870532



J14415