

ASME B16.22-2001
(Revision of ASME B16.22-1995)

WROUGHT COPPER AND COPPER ALLOY SOLDER JOINT PRESSURE FITTINGS

AN AMERICAN NATIONAL STANDARD



The American Society of
Mechanical Engineers



The American Society of
Mechanical Engineers

A N A M E R I C A N N A T I O N A L S T A N D A R D

WROUGHT COPPER AND COPPER ALLOY SOLDER JOINT PRESSURE FITTINGS

ASME B16.22-2001
(Revision of ASME B16.22-1995)

Date of Issuance: August 9, 2002

The next edition of this Standard is scheduled for publication in 2007. There will be no addenda issued to this edition.

ASME issues written replies to inquiries concerning interpretations of technical aspects of this Standard.

ASME is the registered trademark of The American Society of Mechanical Engineers.

This code or standard was developed under procedures accredited as meeting the criteria for American National Standards. The Standards Committee that approved the code or standard was balanced to assure that individuals from competent and concerned interests have had an opportunity to participate. The proposed code or standard was made available for public review and comment that provides an opportunity for additional public input from industry, academia, regulatory agencies, and the public-at-large.

ASME does not "approve," "rate," or "endorse" any item, construction, proprietary device, or activity.

ASME does not take any position with respect to the validity of any patent rights asserted in connection with any items mentioned in this document, and does not undertake to insure anyone utilizing a standard against liability for infringement of any applicable letters patent, nor assumes any such liability. Users of a code or standard are expressly advised that determination of the validity of any such patent rights, and the risk of infringement of such rights, is entirely their own responsibility.

Participation by federal agency representative(s) or person(s) affiliated with industry is not to be interpreted as government or industry endorsement of this code or standard.

ASME accepts responsibility for only those interpretations of this document issued in accordance with the established ASME procedures and policies, which precludes the issuance of interpretations by individuals.

No part of this document may be reproduced in any form,
in an electronic retrieval system or otherwise,
without the prior written permission of the publisher.

The American Society of Mechanical Engineers
Three Park Avenue, New York, NY 10016-5990

Copyright © 2002 by
THE AMERICAN SOCIETY OF MECHANICAL ENGINEERS
All Rights Reserved
Printed in U.S.A.

CONTENTS

Foreword	iv
Standards Committee Roster	vi
1 Scope	1
2 Pressure–Temperature Ratings	1
3 Terminology	2
4 Size	2
5 Marking	2
6 Material	2
7 Laying Lengths	5
8 Tube Stops	5
9 Inspection Tolerance	5
10 Threaded Ends	7
11 Alignment	7
12 Gaging	7
Figures	
1 Method of Designating Laying Lengths of Fittings and Openings of Reducing Fittings	3
2 Tube Stops	5
3 Alignment	7
Tables	
1 Rated Internal Working Pressure for Copper Fittings, kPa	2
2 Inspection Tolerance	5
3 Dimensions of Solder-Joint Ends, mm	6
Mandatory Appendices	
I Strength of Solder Joints	9
II U.S. Customary Equivalents	11
III References	14
Nonmandatory Appendices	
A Fitting Rating	15
B Quality System Program	16

FOREWORD

Standardization of cast and wrought solder-joint fittings was initiated in Subcommittee 11 of American Standards Association (ASA) Sectional Committee A40 on Plumbing Requirements and Equipment. Development work culminated in publication of ASA A40.3-1941. The standard benefited from work done by Mr. A. R. Maupin of the National Bureau of Standards, both before and during its development, on the strength of solder joints.

In 1949, work on these fittings was transferred to Sectional Committee B16, which established Subcommittee 9 (now Subcommittee J) with a scope broader than plumbing applications. The first standard developed was approved as ASA B16.18-1950, Cast-Brass Solder Joint Fittings. It was then decided to revise A40.3 as a B16 standard covering only wrought solder-joint fittings. This effort was facilitated by a 1950 draft prepared by joint effort of the Copper and Brass Research Association and the Manufacturers Standardization Society of the Valve and Fittings Industry (MSS). The draft, after review and approval by Subcommittee 9 and the Sectional Committee, was approved as B16.22-1951.

Revisions were published as ASA B16.22-1963 and, after reorganization of ASA as the American National Standards Institute (ANSI), as ANSI B16.22-1973. In these editions, updated practices, new materials, and new types of fittings were incorporated into the standard, as well as editorial improvements and updating of referenced specifications and standards.

In 1979, Subcommittee I (formerly 9, now J) added metric dimensional equivalents and made other minor improvements. This revision was approved by ANSI, after approval by the Committee and secretariat organizations, as ANSI B16.22-1980.

In 1982, American National Standards Committee B16 was reorganized as an ASME Committee operating under procedures accredited by ANSI.

In 1989, Subcommittee J removed metric equivalents and updated referenced standards.

In 1995, Subcommittee J defined bursting strength, defined standard gaging method for threaded ends, revised solder-joint lengths for $\frac{1}{8}$ in. size external and internal ends, and revised minimum wall-thickness values based on a comprehensive bursting-test study. Following approval by the Standards Committee and ASME, approval as an American National Standard was given by ANSI on July 24, 1995, with the new designation ASME B16.22-1995.

In 1998, editorial revisions, which included the addition of a new section on quality systems and a change in the designation of ASTM B 32 alloys, were issued as an addendum. This addendum to the 1995 edition of ASME B16.22, after approval by the ASME B16 Committee and ASME, was approved as ASME B16.22a-1998.

In this 2001 edition, Subcommittee J converted the physical requirements to SI (metric) units of measure, added requirements for tube stops, clarified ovalate and alignment requirements, and made numerous editorial revisions. Alloy E and Alloy HB were incorporated into the table listing pressure-temperature ratings for the soldering and brazing materials, plus values for the 95-5 tin-antimony solder were revised. These revisions to pressure-temperature ratings reflect the data from a National Institute of Standards and Technology (NIST) solder-joint testing study, initiated in 1993 to develop stress rupture and strength data on copper tube sleeve joints using various solders. Following approval by the Standards

Committee and ASME, approval as an American National Standard was given by ANSI on October 11, 2001, with the new designation ASME B16.22-2001.

Requests for interpretation or suggestions for revision should be sent to the Secretary, B16 Committee, ASME International, Three Park Avenue, New York, NY 10016-5990.

ASME STANDARDS COMMITTEE B16

Standardization of Valves, Flanges, Fittings, and Gaskets

(The following is the roster of the Committee at the time of approval of this Standard.)

OFFICERS

W. N. McLean, *Chair*
H. R. Sonderegger, *Vice Chair*
P. A. Reddington, *Secretary*

COMMITTEE PERSONNEL

R. W. Barnes, Anric Enterprises
R. R. Brodin, Fisher Controls International, Inc.
M. A. Clark, Nibco, Inc.
A. Cohen, Arthur Cohen & Associates
C. E. Floren, Mueller Co.
D. R. Frikken, Solutia, Inc.
G. A. Jolly, Vogt Valve Co.
W. G. Knecht, BW/IP International, Inc.
R. Koester, The William Powell Co.
W. N. McLean, Newco Valves
M. L. Nayyar, Bechtel Power Corp.
P. A. Reddington, The American Society of Mechanical Engineers
R. A. Schmidt, Trinity-Ladish Co.
H. R. Sonderegger, Grinnell Corp.
W. M. Stephan, Flexitallic Inc.
T. F. Stroud, Ductile Iron Pipe Research Association
R. E. White, Richard E. White and Associates
D. A. Williams, Southern Company Services
L. A. Willis, Dow Chemical Co.
W. R. Worley, Union Carbide Corp.

SUBCOMMITTEE J — COPPER AND COPPER ALLOY FLANGES, FLANGED FITTINGS, AND SOLDER JOINT FITTINGS

M. A. Clark, *Chair*, Nibco, Inc.
G. Moino, *Secretary*, The American Society of Mechanical Engineers
D. F. Buccicone, Elkhart Products Corp.
A. Cohen, Arthur Cohen & Associates
D. R. Frikken, Solutia, Inc.
A. G. Kireta, Jr., Copper Development Association, Inc.
A. A. Knapp, Canadian Copper/Brass Development Association
L. McDaniel, Mueller Copper Fittings, LP
T. L. Jamison, *Alternate*, Mueller Industries

WROUGHT COPPER AND COPPER ALLOY SOLDER JOINT PRESSURE FITTINGS

1 SCOPE

1.1 General

This Standard establishes specifications for wrought copper and wrought copper alloy, solder-joint, seamless fittings, designed for use with seamless copper tube conforming to ASTM B 88 (water and general plumbing systems), B 280 (air conditioning and refrigeration service), and B 819 (medical gas systems), as well as fittings intended to be assembled with soldering materials conforming to ASTM B 32, brazing materials conforming to AWS A5.8, or with tapered pipe thread conforming to ASME B1.20.1.

This Standard is allied with ASME B16.18, which covers cast copper alloy pressure fittings. It provides requirements for fitting ends suitable for soldering. This Standard covers:

- (a) pressure-temperature ratings;
- (b) abbreviations for end connections;
- (c) size and method of designating openings of fittings;
- (d) marking;
- (e) material;
- (f) dimensions and tolerances; and
- (g) tests.

1.2 Convention

For the purpose of determining conformance with this Standard, the convention for fixing significant digits where limits (maximum or minimum values) are specified shall be *rounding off* as defined in ASTM E 29. This requires that an observed or calculated value shall be rounded off to the nearest unit in the last right-hand digit used for expressing the limit.

1.3 Units of Measure

The values stated in either SI (metric) or U.S. customary (in.-lb) units of measure shall be regarded separately as standard. Within the main text, SI units are given. For convenience, the customary units are shown in Mandatory Appendix II. The values stated

in each system are not exact equivalents; therefore, each system shall be used independently of the other.

NOTE: Combining values from the two systems may result in nonconformance with the Standard.

1.4 References

Standards and specifications adopted by reference in this Standard are shown in Mandatory Appendix III. It is not considered practical to identify the specific edition of each standard and specification in the individual references. Instead, the specific edition reference is identified in Appendix III.

1.5 Quality Systems

Requirements relating to the product manufacturer's quality system program are described in Nonmandatory Appendix B.

2 PRESSURE-TEMPERATURE RATINGS

2.1 Rating of Fittings and Joints

The internal working pressure-temperature rating for a solder-joint system is dependent upon not only fitting and tube strength, but also composition of the solder used for the joint and selection of valves and appurtenances.

Pressure-temperature ratings for solder joints to the dimensions of Table 3 (Table II3), made with typical commercial solders, are given in Table I1 (Table II4).

The internal working-pressure rating of the system shall be the lowest of the values shown in Table 1 (Table II1) and Table I1 (Table II4), and those of the tube, valves, or appurtenances.

2.2 Bursting Strength

Fittings manufactured to the Standard shall have an ambient temperature bursting strength of at least four times the 38°C (100°F) rated internal working pressure as shown in Table 1 (Table II1).

**TABLE 1 RATED INTERNAL WORKING PRESSURE FOR COPPER
FITTINGS, kPa**

Standard Water Tube Size [Note (1)]	-29 to 38°C	66°C	93°C	121°C	149°C	177°C	204°C
1/4	6280	5340	5020	5020	4920	4190	3140
3/8	5360	4560	4290	4290	4200	3570	2680
1/2	4970	4220	3980	3980	3890	3310	2480
5/8	4350	3700	3480	3480	3410	2900	2170
3/4	4010	3410	3210	3210	3140	2670	2000
1	3400	2890	2720	2720	2660	2270	1700
1 1/4	3020	2570	2420	2420	2370	2010	1510
1 1/2	2810	2390	2250	2250	2200	1870	1400
2	2500	2130	2000	2000	1960	1670	1250
2 1/2	2310	1960	1850	1850	1810	1540	1150
3	2180	1850	1740	1740	1710	1450	1090
3 1/2	2090	1770	1670	1670	1630	1390	1040
4	2020	1710	1610	1610	1580	1340	1010
5	1850	1570	1480	1480	1450	1230	920
6	1720	1460	1380	1380	1350	1150	860
8	1860	1580	1490	1490	1460	1240	930

GENERAL NOTES:

- (a) The fitting pressure rating applies to the largest opening of the fitting.
 (b) The fitting pressure rating is calculated as shown in Nonmandatory Appendix A, then rounded down to the nearest unit of 10.

NOTE:

- (1) For size designation of fittings, see para. 4.

3 TERMINOLOGY**3.1 Abbreviations**

The following symbols are used to designate the type of fitting end:

- C = solder-joint fitting end made to receive copper tube diameter (female)
 F = internal ANSI standard taper pipe-thread end (female) NPTI
 FTG = solder-joint fitting end made to copper tube diameter (male)
 M = external ANSI standard taper pipe-thread end (male) NPTE

3.2 Definitions

out-of-roundness: maximum measured diameter minus minimum measured diameter.

ovality: elliptical condition associated with out-of-roundness.

4 SIZE

The size of the fittings shown in Table 3 (Table II3) corresponds to standard water tube size as shown in ASTM B 88. The size of the threaded ends corresponds to nominal pipe size as shown in ASME B1.20.1.

Fittings are designated by the size of the openings in the sequence illustrated in Fig. 1.

5 MARKING

Each fitting shall be permanently marked with the manufacturer's name or trademark in accordance with MSS SP-25. Marking on fittings less than size 1/2 or on any fitting where it damages soldering surfaces is not required.

6 MATERIAL

(a) Fittings shall be made from copper UNS Nos. C10200, C12000, or C12200, or copper alloy UNS

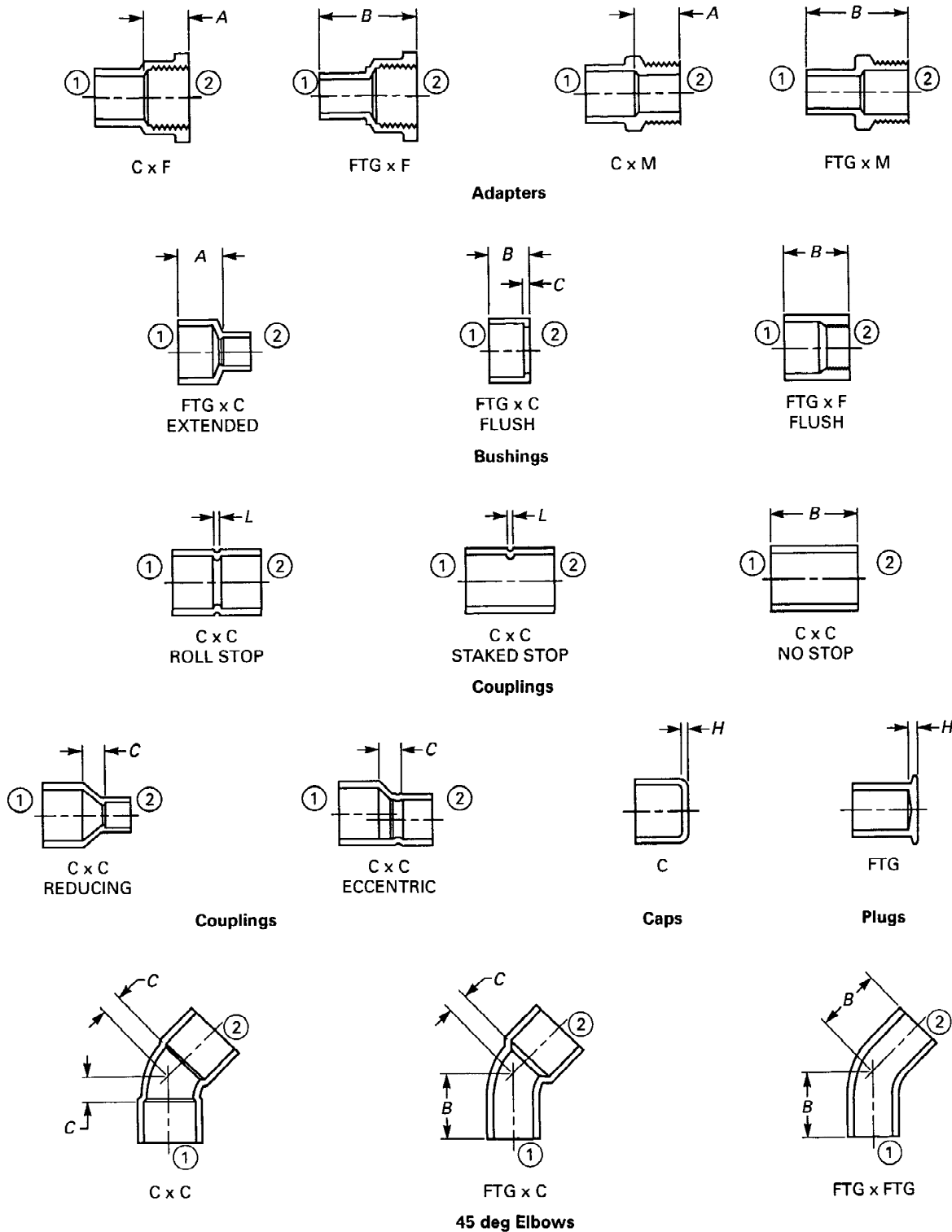
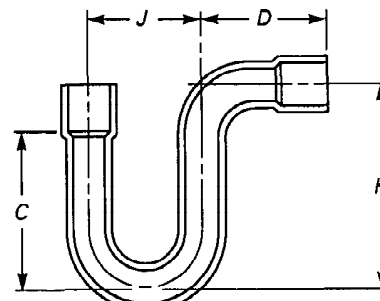
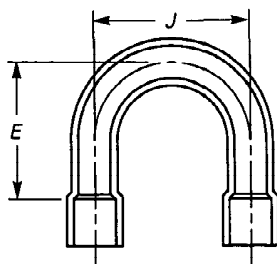
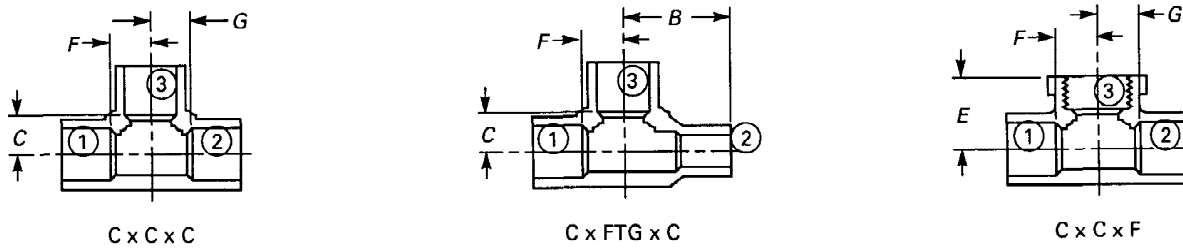
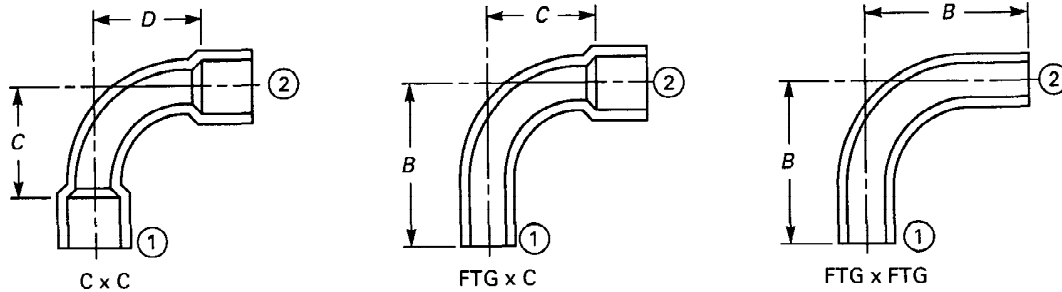
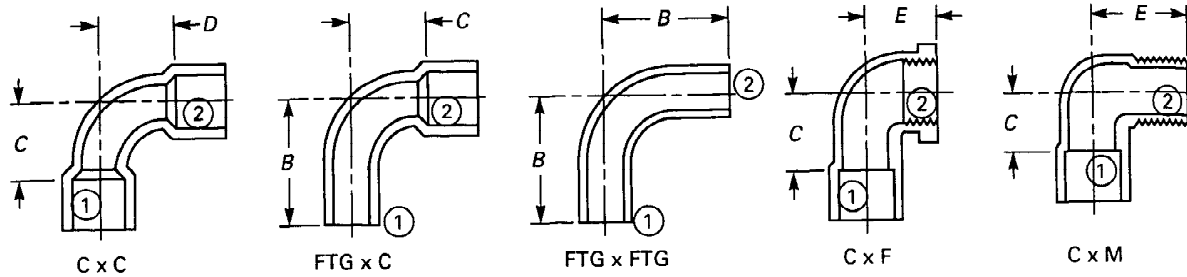

FIG. 1 METHOD OF DESIGNATING LAYING LENGTHS OF FITTINGS AND OPENINGS OF REDUCING FITTINGS



GENERAL NOTES:

- (a) Fittings are designated by size in the order: ① x ② x ③.
- (b) Fitting designs and drawings are illustrative only.

FIG. 1 METHOD OF DESIGNATING LAYING LENGTHS OF FITTINGS AND OPENINGS OF REDUCING FITTINGS (CONT'D)

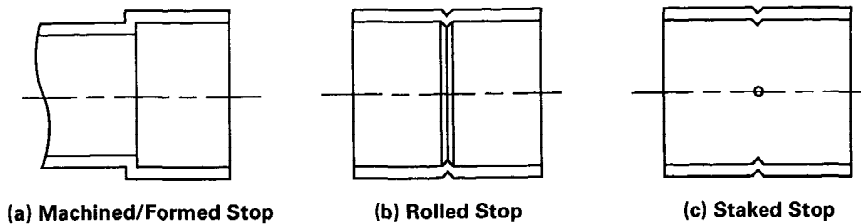

GENERAL NOTE: This figure is for illustration only; the shape and number of abutments shall be at the manufacturer's discretion.

FIG. 2 TUBE STOPS

No. C23000, for which allowable stresses are found in ASME B31.1, ASME B31.9, or ASME Boiler and Pressure Vessel Code, Section II — Materials.

(b) Other coppers and copper alloys are permitted, provided they meet the chemical requirements of 84% minimum copper and 16% maximum zinc, and provided the fittings produced from the copper alloy meet all the mechanical and corrosion-resistant properties for the end purposes of the fittings. The composition of the copper alloy shall contain nothing that will inhibit joining to the tube or to other fittings.

7 LAYING LENGTHS

Due to widely varying manufacturing processes, meaningful laying length requirements of fittings cannot be established. Consult the manufacturer for these dimensions.

8 TUBE STOPS

Except for repair couplings, fittings shall be manufactured with a tube stop. Repair couplings shall not require a tube stop. The tube stop shall control joint length, even with an external (FTG) end having the minimum outside diameter shown in Table 3 (Table II3). Examples of various tube stop configurations are shown in Fig. 2.

9 INSPECTION TOLERANCE

9.1 Linear Dimensions

An inspection tolerance, as shown in Table 2 (Table II2), shall be allowed on center-to-shoulder, center-to-center, center-to-threaded-end, and shoulder-to-threaded-end dimensions on all fittings having internal (C) solder ends, as well as on center-to-solder-end and

TABLE 2 INSPECTION TOLERANCE

Standard Water Tube and Pipe Thread Sizes	Tolerance, Plus or Minus, mm
$\frac{1}{8}$, $\frac{1}{4}$, $\frac{3}{8}$ [Note (1)]	1.3
$\frac{1}{2}$, $\frac{5}{8}$, $\frac{3}{4}$	1.5
1, $1\frac{1}{4}$, $1\frac{1}{2}$, 2	2.0
$2\frac{1}{2}$, 3, $3\frac{1}{2}$	2.8
4 and 5	3.0
6 and 8	4.1

NOTE:

(1) $\frac{1}{8}$ size is $\frac{1}{4}$ O.D. seamless copper tube for refrigeration service, etc., as listed in ASTM B 280.

solder-end-to-threaded-end dimensions on all fittings having external (FTG) solder ends.

Coupling inspection limits for shoulder-to-shoulder and shoulder-to-end dimensions shall be double those shown in Table 2 (Table II2), except that the minus tolerance applied to dimension L (see Fig. 1) shall not result in a dimension less than 1.5 mm (0.06 in.).

The largest opening in the fitting shall govern the tolerance to be applied to all openings.

9.2 Ovality of Fitting End (C or FTG)

Maximum ovality of the fitting solder-joint end shall not exceed 1% of the maximum diameters shown in Table 3 (Table II3). The average of the maximum and minimum diameters shall be within the dimensions shown in the Table.

9.3 Inside Diameter of Fitting

The minimum cross-sectional area of the inside diameter through the fitting body shall not be less than the theoretical minimum area defined by diameter O in Table 3 (Table II3). The out-of-roundness condition of

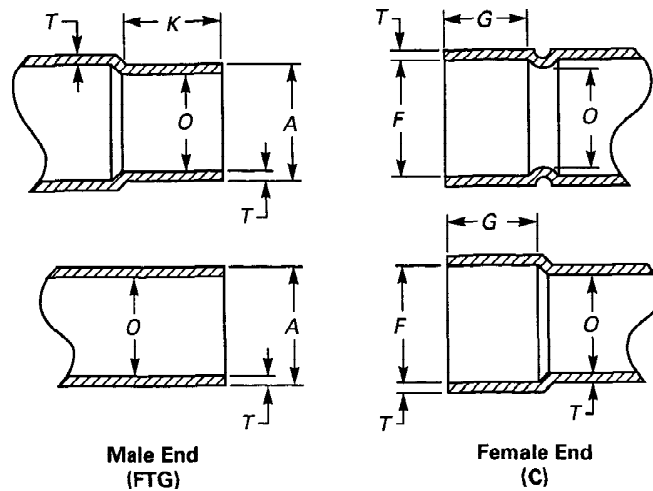

TABLE 3 DIMENSIONS OF SOLDER-JOINT ENDS, mm

Standard Water Tube Size [Note (1)]	External End		Internal End			Wall Thickness T	Inside Diameter of Fitting O		
	Outside Diameter A	Length K	Inside Diameter F	Depth G	Out-of- Roundness, Max.				
	Min.	Max. [Note (2)]	Min. [Note (3)]	Min.	Max. [Note (2)]	Min. [Note (4)]	Min.	Max.	
1/8 [Note (5)]	6.30	6.38	7.9	6.40	6.50	6.4	0.48	4.6	0.5
1/4	9.47	9.55	9.7	9.58	9.88	7.9	0.58	7.6	0.8
3/8	12.62	12.73	11.2	12.75	12.85	9.7	0.66	9.9	1.0
1/2	15.80	15.90	14.2	15.93	16.03	12.7	0.74	13.2	1.3
5/8	18.97	19.08	17.5	19.10	19.20	15.7	0.79	16.0	1.6
3/4	22.15	22.25	20.6	22.28	22.38	19.1	0.84	18.8	1.9
1	28.50	28.63	24.6	28.65	28.75	23.1	1.02	24.9	2.5
1 1/4	34.85	34.98	26.2	35.00	35.10	24.6	1.12	31.2	3.1
1 1/2	41.17	41.33	29.5	41.35	41.48	27.7	1.30	37.3	3.7
2	53.87	54.03	35.8	54.05	54.18	34.0	1.50	49.3	4.9
2 1/2	66.57	66.73	38.9	66.75	66.88	37.3	1.70	61.5	6.1
3	79.27	79.43	43.7	79.45	79.58	42.2	1.91	73.4	7.3
3 1/2	91.97	92.13	50.0	92.15	92.28	48.5	2.18	85.6	8.6
4	104.67	104.83	56.4	104.85	104.98	54.9	2.44	97.5	9.8
5	130.07	130.23	69.1	130.25	130.38	67.6	2.82	119.4	11.9
6	155.47	155.63	81.8	155.65	155.78	78.5	3.15	145.3	14.5
8	206.22	206.43	103.9	206.45	206.58	100.8	4.39	191.8	19.2

GENERAL NOTE: Drawings and designs of fittings are illustrative only. Dimensions herein shall govern in all cases.

NOTES:

- (1) For size designation of fittings, see para. 4.
- (2) For ovality, see para. 8.2.
- (3) The distance from the point of tangency, at the gage I.D. to the gage line, shall be equal to the dimension shown in this column.
- (4) The distance from the point of tangency, at the gage O.D. to the gage line, shall be equal to the dimension shown in this column.
- (5) 1/8 size is 1/4 O.D. seamless copper tube for refrigeration service, etc., as listed in ASTM B 280.

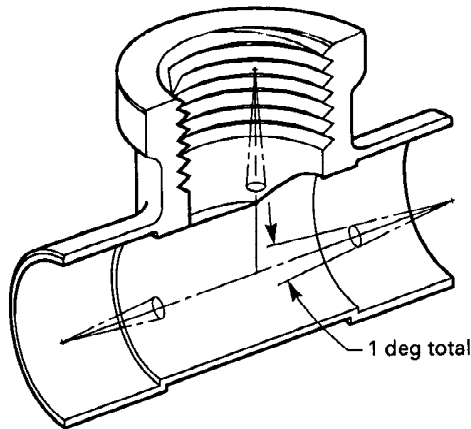

GENERAL NOTE: This figure is for illustration only.

FIG. 3 ALIGNMENT

the cross-sectional area shall not exceed the value shown in Table 3 (Table II3).

For reducer or adapter fittings, the smallest end diameter shall apply, provided that this diameter does not restrict the other outlets.

9.4 Wall Thickness

The minimum wall thickness shall not be less than that shown in Table 3 (Table II3).

10 THREADED ENDS

Fitting threads shall be right-hand, conforming to ASME B1.20.1. They shall be taper threads (NPT).

10.1 Countersink or Chamfer

All internal threads shall be countersunk a distance no less than one-half the pitch of the thread, at an angle of approximately 45 deg with the axis of the thread. All external threads shall be chamfered at an angle of 30–45 deg from the axis. Countersinking and chamfering shall be concentric with the threads.

The length of threads shall be measured to include the countersink or chamfer.

10.2 Threading Tolerances

Tapered pipe threads (NPT) shall be checked by use of plug or ring gages in either standard or limit types. When gaging internal taper threads, the plug gage shall be screwed hand-tight into the fitting. The reference point for gaging internal product threads depends on the chamfer diameter. When the internal chamfer diameter

exceeds the major diameter of the internal thread, the reference point shall be the last thread scratch on the chamfer cone. Otherwise, when the internal chamfer diameter does not exceed the major diameter of the internal thread, the reference point shall be the end of the fitting. In gaging external taper threads, the ring gage shall be screwed hand-tight on the external thread. On the external thread, the ring gage shall be flush with the end of the thread.

Tolerance for an internal threaded end having an internal shoulder shall be from the gage reference point (notch) to one turn small. Tolerance for an internally threaded end without a shoulder, and for an externally threaded end, shall be from one turn small to one turn large.

10.3 Design of Threaded Ends

The wrenching section of internally threaded ends shall be polygonal, and the wrenching section of externally threaded ends shall be furnished with either polygon or flats, at the manufacturer's option.

11 ALIGNMENT

The maximum allowable deviation in the angular alignment of any end from the specified axis position shall be $\frac{1}{2}$ deg (1 deg total). See Fig. 3.

12 GAGING

12.1 Preferred Gaging Method of Solder-Joint Ends

The preferred method of gaging the diameter tolerances for external and internal ends shall be by the use of plain plug and ring gages designed to hold the product within the limits established in Table 3 (Table II3). Gage tolerances shall be Class ZM, as defined in ASME B4.4M.

12.2 Optional Gaging Method of Solder-Joint Ends

For gaging the diameter tolerance of external and internal ends, the use of direct reading instruments instead of ring and plug gages as specified in para. 12.1 shall be permitted. When gaging the diameters of external and internal ends using direct reading instruments, refer to para. 9.2.

12.3 Standard Gaging Method of Threaded Ends

The standard method of gaging the externally and internally threaded ends shall be in accordance with the requirements of ASME B1.20.1.

NOTE: In gaging pipe threads, it is acceptable and common practice to rap or tap the part to assure proper seating of the gage. However, it is first necessary to clean both the gage and the product threads to assure that they are free of chips, burrs, abrasives, or other foreign materials.

MANDATORY APPENDIX I STRENGTH OF SOLDER JOINTS

The maximum recommended pressure–temperature ratings for solder joints made with copper tube and wrought copper and copper alloy pressure fittings, using representative commercial solders, are listed in Table I1. These pressure–temperature ratings are based on solder joints made in accordance with the requirements of ASTM B 828.

TABLE 11 PRESSURE-TEMPERATURE RATINGS

Joining Material	Working Temperature, °C	Maximum Gage Working Pressure for Standard Water Tube Sizes, kPa [Note (1)]			
		1/8 Through 1	1/4 Through 2	2 1/2 Through 4	5 Through 8
Alloy Sn50 50-50 tin-lead solder [Notes (2), (3)]	38	1375	1205	1030	930
	66	1030	860	685	620
	93	685	620	515	480
	121	585	515	340	310
Alloy Sb5 95-5 tin-antimony solder [Note (4)]	38	7540 (8)	5880 (9)	4880 (9)	4555 (9)
	66	4315 (10)	3365 (10)	2790 (10)	2605 (10)
	93	3500 (11)	2730 (10)	2265 (10)	2115 (10)
	121	1885	1475	1220	1135
Alloy E [Note (5)]	38	4905 (10)	3825 (10)	3175 (10)	2965 (10)
	66	3275 (11)	2550 (10)	2115 (10)	1975 (11)
	93	2595	2025	1680 (11)	1570 (11)
	121	2230	1735	1440	1340
Alloy HB [Note (6)]	38	7135 (8)	5560 (9)	4615 (9)	4305 (8)
	66	4905 (10)	3825 (10)	3175 (10)	2965 (10)
	93	3045 (11)	2375 (11)	1970 (11)	1840 (11)
	121	2970 (11)	2315 (11)	1920 (11)	1800 (11)
Joining materials melting at or above 593°C [Note (7)]		Pressure-temperature ratings consistent with the materials and procedures employed			

GENERAL NOTE: For extremely low working temperatures in the -18°C to -93°C range, it is recommended that a joint material melting at or above 593°C be employed [see Note (5)].

NOTES:

- (1) Standard water tube sizes per ASTM B 88.
- (2) ASTM B 32 Alloy Grade Sn50.
- (3) The Safe Drinking Water Act Amendments of 1986 prohibit the use of any solder having a lead content in excess of 0.2% in potable water systems.
- (4) ASTM B 32 Alloy Grade Sb5.
- (5) ASTM B 32 Alloy Grade E.
- (6) ASTM B 32 Alloy Grade HB.
- (7) These joining materials are defined as *brazing alloys* by the American Welding Society.
- (8) The solder joint exceeds the strength of Types L and M tube in drawn temper and Type K tube in annealed temper.
- (9) The solder joint exceeds the strength of Types K, L, and M tube in drawn and annealed tempers.
- (10) The solder joint exceeds the strength of Type M tube in drawn temper and Types L and K in annealed temper.
- (11) The solder joint exceeds the strength of Type L tube in annealed temper.

MANDATORY APPENDIX II U.S. CUSTOMARY EQUIVALENTS

**TABLE II1 RATED INTERNAL WORKING PRESSURE FOR COPPER
FITTINGS, psi**

Standard Water Tube Size [Note (1)]	-20 to 100°F	150°F	200°F	250°F	300°F	350°F	400°F
1/4	910	770	725	725	710	605	455
3/8	775	660	620	620	610	515	385
1/2	720	610	575	575	565	480	360
5/8	630	535	505	505	490	420	315
3/4	580	490	465	465	455	385	290
1	490	420	395	395	385	325	245
1 1/4	435	370	350	350	340	290	215
1 1/2	405	345	325	325	315	270	200
2	360	305	290	290	280	240	180
2 1/2	335	285	265	265	260	220	165
3	315	265	250	250	245	210	155
3 1/2	300	255	240	240	235	200	150
4	290	245	230	230	225	195	145
5	265	225	215	215	210	175	130
6	250	210	200	200	195	165	125
8	270	225	215	215	210	180	135

GENERAL NOTES:

- (a) The fitting pressure rating applies to the largest opening of the fitting.
 (b) The fitting pressure rating is calculated as shown in Nonmandatory Appendix A, then rounded down to the nearest unit of 5.

NOTE:

- (1) For size designation of fittings, see para. 4.

TABLE II2 INSPECTION TOLERANCE

Standard Water Tube and Pipe Thread Sizes	Tolerance, Plus or Minus, in.
1/8, 1/4, 3/8 [Note (1)]	0.05
1/2, 5/8, 3/4	0.06
1, 1 1/4, 1 1/2, 2	0.08
2 1/2, 3, 3 1/2	0.11
4 and 5	0.12
6 and 8	0.16

NOTE:

- (1) 1/8 size is 1/4 O.D. seamless copper tube for refrigeration service, etc., as listed in ASTM B 280.

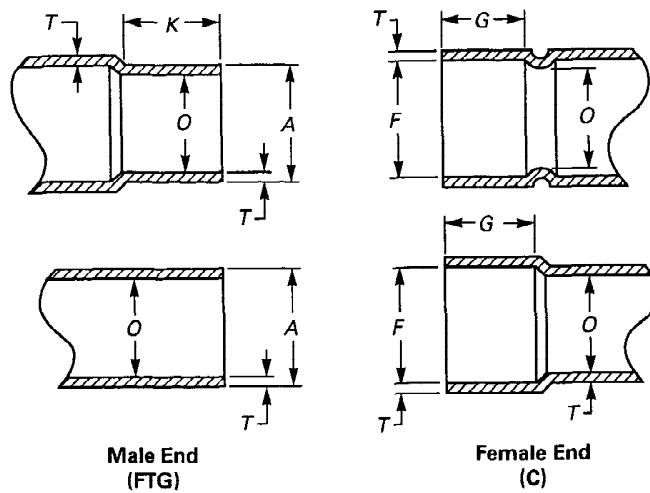

TABLE II3 DIMENSIONS OF SOLDER-JOINT ENDS, in.

Standard Water Tube Size [Note (1)]	External End			Internal End			Wall Thickness T	Inside Diameter of Fitting O	
	Outside Diameter A	Length K		Inside Diameter F	Depth G			Dia., Min.	Out-of- Roundness, Max.
	Min.	Max. [Note (2)]	Min. [Note (3)]	Min.	Max. [Note (2)]	Min. [Note (4)]	Min.		
1/8 [Note (5)]	0.248	0.251	0.31	0.252	0.256	0.25	0.019	0.18	0.02
1/4	0.373	0.376	0.38	0.377	0.381	0.31	0.023	0.30	0.03
3/8	0.497	0.501	0.44	0.502	0.506	0.38	0.026	0.39	0.04
1/2	0.622	0.626	0.56	0.627	0.631	0.50	0.029	0.52	0.05
5/8	0.747	0.751	0.69	0.752	0.756	0.62	0.031	0.63	0.06
3/4	0.872	0.876	0.81	0.877	0.881	0.75	0.033	0.74	0.07
1	1.122	1.127	0.97	1.128	1.132	0.91	0.040	0.98	0.10
1 1/4	1.372	1.377	1.03	1.378	1.382	0.97	0.044	1.23	0.12
1 1/2	1.621	1.627	1.16	1.628	1.633	1.09	0.051	1.47	0.15
2	2.121	2.127	1.41	2.128	2.133	1.34	0.059	1.94	0.19
2 1/2	2.621	2.627	1.53	2.628	2.633	1.47	0.067	2.42	0.24
3	3.121	3.127	1.72	3.128	3.133	1.66	0.075	2.89	0.29
3 1/2	3.621	3.627	1.97	3.628	3.633	1.91	0.086	3.37	0.34
4	4.121	4.127	2.22	4.128	4.133	2.16	0.096	3.84	0.38
5	5.121	5.127	2.72	5.128	5.133	2.66	0.111	4.70	0.47
6	6.121	6.127	3.22	6.128	6.133	3.09	0.124	5.72	0.57
8	8.119	8.127	4.09	8.128	8.133	3.97	0.173	7.55	0.76

GENERAL NOTE: Drawings and designs of fittings are illustrative only. Dimensions herein shall govern in all cases.

NOTES:

- (1) For size designation of fittings, see para. 4.
- (2) For ovality, see para. 8.2.
- (3) The distance from the point of tangency, at the gage I.D. to the gage line, shall be equal to the dimension shown in this column.
- (4) The distance from the point of tangency, at the gage O.D. to the gage line, shall be equal to the dimension shown in this column.
- (5) 1/8 size is 1/4 O.D. seamless copper tube for refrigeration service, etc., as listed in ASTM B 280.

TABLE II4 PRESSURE-TEMPERATURE RATINGS

Joining Material	Working Temperature, °F	Maximum Gage Working Pressure for Standard Water Tube Sizes, psi [Note (1)]			
		$\frac{1}{8}$	$1\frac{1}{4}$	$2\frac{1}{2}$	5
		Through 1	Through 2	Through 4	Through 8
Alloy Sn50 50-50 tin-lead solder [Notes (2), (3)]	100	200	175	150	135
	150	150	125	100	90
	200	100	90	75	70
	250	85	75	50	45
Alloy Sb5 95-5 tin-antimony solder [Note (4)]	100	1090 (8)	850 (9)	705 (9)	660 (9)
	150	625 (10)	485 (10)	405 (10)	375 (10)
	200	505 (11)	395 (10)	325 (10)	305 (10)
	250	270	210	175	165
Alloy E [Note (5)]	100	710 (10)	555 (10)	460 (10)	430 (10)
	150	475 (11)	370 (10)	305 (10)	285 (11)
	200	375	290	240 (11)	225 (11)
	250	320	250	205	195
Alloy HB [Note (6)]	100	1035 (8)	805 (9)	670 (9)	625 (8)
	150	710 (10)	555 (10)	460 (10)	430 (10)
	200	440 (11)	345 (11)	285 (11)	265 (11)
	250	430 (11)	335 (11)	275 (11)	260 (11)
Joining materials melting at or above 1,100°F [Note (7)]	Pressure-temperature ratings consistent with the materials and procedures employed				

GENERAL NOTE: For extremely low working temperatures in the 0°F to -200°F range, it is recommended that a joint material melting at or above 1,100°F be employed [see Note (5)].

NOTES:

- (1) Standard water tube sizes per ASTM B 88.
- (2) ASTM B 32 Alloy Grade Sn50.
- (3) The Safe Drinking Water Act Amendments of 1986 prohibit the use of any solder having a lead content in excess of 0.2% in potable water systems.
- (4) ASTM B 32 Alloy Grade Sb5.
- (5) ASTM B 32 Alloy Grade E.
- (6) ASTM B 32 Alloy Grade HB.
- (7) These joining materials are defined as *brazing alloys* by the American Welding Society.
- (8) The solder joint exceeds the strength of Types L and M tube in drawn temper and Type K tube in annealed temper.
- (9) The solder joint exceeds the strength of Types K, L, and M tube in drawn and annealed tempers.
- (10) The solder joint exceeds the strength of Type M tube in drawn temper and Types L and K in annealed temper.
- (11) The solder joint exceeds the strength of Type L tube in annealed temper.

MANDATORY APPENDIX III REFERENCES

The following is a list of standards and specifications referenced in this Standard, showing the year of approval.

ASME B1.20.1-1983 (R2001), Pipe Threads, General Purpose (Inch)¹

ASME B4.4M-1981 (R1994), Inspection of Workpieces¹

ASME B16.18-1984 (R1994), Cast Copper Alloy Solder Joint Pressure Fittings¹

ASME B31.1-1998, Power Piping¹

ASME B31.9-1996, Building Services Piping¹

2001 ASME Boiler and Pressure Vessel Code, Section II, Part B — Nonferrous Material Specifications¹

Publisher: The American Society of Mechanical Engineers (ASME International), Three Park Avenue, New York, NY 10016-5990; Order Department: 22 Law Drive, Box 2300, Fairfield, NJ 07007-2300

ASTM B 32-96, Specification for Solder Metal

ASTM B 88-96, Specification for Seamless Copper Water Tube

ASTM B 280-97, Specification for Seamless Copper Tube for Air Conditioning and Refrigeration Field Service

ASTM B 819-00, Specification for Seamless Copper Tube for Medical Gas Systems

ASTM B 828-00, Standard Practice for Making Capillary Joints by Soldering of Copper and Copper Alloy Tube and Fittings

ASTM E 29-93a, Practice for Using Significant Digits in Test Data to Determine Conformance with Specifications

¹ May also be obtained from American National Standards Institute, 25 West 43rd Street, New York, NY 10036.

Publisher: American Society for Testing and Materials (ASTM), 100 Barr Harbor Drive, West Conshohocken, PA 19428-2959

AWS A5.8-92, Specification for Filler Metals for Brazing and Braze Welding¹

Publisher: American Welding Society (AWS), 550 NW Le Jeune Road, Miami, FL 33126

ISO 9000-1:1994, Quality management and quality assurance standards — Part 1: Guidelines for selection and use

ISO 9000-2:1997, Quality management and quality assurance standards — Part 2: Generic guidelines for the application of ISO 9001, ISO 9002, and ISO 9003

ISO 9000-3:1991, Quality management and quality assurance standards — Part 3: Guidelines for the application of ISO 9001 to the development, supply, and maintenance of software

ISO 9001:1994, Quality systems — Model for quality assurance in design, development, production, installation, and servicing

ISO 9002:1994, Quality systems — Model for quality assurance in production and servicing

ISO 9003:1994, Quality systems — Model for quality assurance in final inspection and test

Publisher: International Organization for Standardization (ISO), 1 rue de Varembe, Case Postale 56, CH-1211, Genève 20, Switzerland/Suisse

MSS SP-25-1998, Standard Marking System for Valves, Fittings, Flanges and Unions

Publisher: Manufacturers Standardization Society of the Valve and Fittings Industry, 127 Park Street, NE, Vienna, VA 22180

NONMANDATORY APPENDIX A FITTING RATING

The rated internal working pressures of the fitting are shown in Table 1 (Table II). These values are the same as those calculated for annealed temper ASTM B 88 Type L copper water tube. The rated internal working pressures for annealed temper ASTM B 88 Type L copper water tube are calculated as follows:

$$p = \frac{2St}{D - 0.8t}$$

where

- D = maximum outside diameter, mm (in.), for annealed temper ASTM B 88 Type L water tube
- p = rated working pressure at temperature, kPa (psi)
- S = allowable stress at temperature, kPa (psi), from ASME B31.1 or ASME B31.9, for annealed temper ASTM B 88 Type L copper water tube
- t = minimum wall thickness, mm (in.), for annealed temper ASTM B 88 Type L water tube

Interpretation: 22-1

Subject: ASME B16.22-1995, Paragraph 8.3, Wall Thickness

Date Issued: April 7, 1999

File: B16-98-007

Question: Does the minimum wall thickness requirement apply to any location in the fitting?

Reply: Yes.

AMERICAN NATIONAL STANDARDS FOR PIPING, PIPE FLANGES, FITTINGS, AND VALVES

Scheme for the Identification of Piping Systems	A13.1-1996
Pipe Threads, General Purpose (Inch)	B1.20.1-1983 (R1992)
Dryseal Pipe Threads (Inch)	B1.20.3-1976 (R1998)
Cast Iron Pipe Flanges and Flanged Fittings: Classes 25, 125, and 250	B16.1-1998
Malleable Iron Threaded Fittings: Classes 150 and 300	B16.3-1998
Gray Iron Threaded Fittings: Classes 125 and 250	B16.4-1998
Pipe Flanges and Flanged Fittings (NPS ½ Through NPS 24)	B16.5-1996
Factory-Made Wrought Butt welding Fittings	B16.9-2001
Face-to-Face and End-to-End Dimensions of Valves	B16.10-2000
Forged Fittings, Socket-Welding and Threaded	B16.11-2001
Cast Iron Threaded Drainage Fittings	B16.12-1998
Ferrous Pipe Plugs, Bushings, and Locknuts with Pipe Threads	B16.14-1991
Cast Bronze Threaded Fittings: Classes 125 and 250	B16.15-1985 (R1994)
Cast Copper Alloy Solder Joint Pressure Fittings	B16.18-2001
Metallic Gaskets for Pipe Flanges: Ring-Joint, Spiral-Wound, and Jacketed	B16.20-1998
Nonmetallic Flat Gaskets for Pipe Flanges	B16.21-1992
Wrought Copper and Copper Alloy Solder Joint Pressure Fittings	B16.22-2001
Cast Copper Alloy Solder Joint Drainage Fittings — DWV	B16.23-1992
Cast Copper Alloy Pipe Flanges and Flanged Fittings: Class 150, 300, 400, 600, 900, 1500, and 2500	B16.24-2001
Butt welding Ends	B16.25-1997
Cast Copper Alloy Fittings for Flared Copper Tubes	B16.26-1988
Wrought Steel Butt welding Short Radius Elbows and Returns	B16.28-1994
Wrought Copper and Wrought Copper Alloy Solder Joint Drainage Fittings — DWV	B16.29-2001
Manually Operated Metallic Gas Valves for Use in Gas Piping Systems up to 125 psig (Sizes ½ Through 2)	B16.33-1990
Valves — Flanged, Threaded, and Welding End	B16.34-1996
Orifice Flanges	B16.36-1996
Large Metallic Valves for Gas Distribution (Manually Operated, NPS 2½ to 12, 125 psig Maximum)	B16.38-1985 (R1994)
Malleable Iron Threaded Pipe Unions	B16.39-1998
Manually Operated Thermoplastic Gas Shutoffs and Valves in Gas Distribution Systems	B16.40-2002
Functional Qualification Requirements for Power Operated Active Valve Assemblies for Nuclear Power Plants	B16.41-1983 (R1989)
Ductile Iron Pipe Flanges and Flanged Fittings, Classes 150 and 300	B16.42-1998
Manually Operated Metallic Gas Valves for Use in House Piping Systems	B16.44-1995
Cast Iron Fittings for Solvent® Drainage Systems	B16.45-1998
Large Diameter Steel Flanges (NPS 26 Through NPS 60)	B16.47-1996
Steel Line Blanks	B16.48-1997
Factory-Made Wrought Steel Butt welding Induction Bends for Transportation and Distribution Systems	B16.49-2000
Wrought Copper and Copper Alloy Braze-Joint Pressure Fittings	B16.50-2001
Power Piping	B31.1-2001
Fuel Gas Piping (not an ANSI standard)	B31.2-1968
Process Piping	B31.3-2002
Pipeline Transportation Systems for Liquid Hydrocarbons and Other Liquids	B31.4-1998
Refrigeration Piping and Heat Transfer Components	B31.5-2001
Gas Transmission and Distribution Piping Systems	B31.8-1999
Building Services Piping	B31.9-1996
Slurry Transportation Piping Systems	B31.11-1989 (R1998)
Manual for Determining the Remaining Strength of Corroded Pipelines	B31G-1991
Welded and Seamless Wrought Steel Pipe	B36.10M-1996
Stainless Steel Pipe	B36.19M-1985 (R1994)
Self-Operated and Power-Operated Safety-Related Valves Functional Specification Standard	N278.1-1975 (R1992)

The ASME Publications Catalog shows a complete list of all the Standards published by the Society. For a complimentary catalog, or the latest information about our publications, call 1-800-THE-ASME (1-800-843-2763).

ASME Services

ASME is committed to developing and delivering technical information. At ASME's Information Central, we make every effort to answer your questions and expedite your orders. Our representatives are ready to assist you in the following areas:

ASME Press
Codes & Standards
Credit Card Orders
IMEchE Publications
Meetings & Conferences
Member Dues Status

Member Services & Benefits
Other ASME Programs
Payment Inquiries
Professional Development
Short Courses
Publications

Public Information
Self-Study Courses
Shipping Information
Subscriptions/Journals/Magazines
Symposia Volumes
Technical Papers

How can you reach us? It's easier than ever!

There are four options for making inquiries* or placing orders. Simply mail, phone, fax, or E-mail us and an Information Central representative will handle your request.

Mail
ASME
22 Law Drive, Box 2900
Fairfield, New Jersey
07007-2900

Call Toll Free
US & Canada: 800-THE-ASME
(800-843-2763)
Mexico: 95-800-THE-ASME
(95-800-843-2763)
Universal: 973-882-1167

Fax—24 hours
973-882-1717
973-882-5155

E-Mail—24 hours
Infocentral@asme.org

* Information Central staff are not permitted to answer inquiries about the technical content of this code or standard. Information as to whether or not technical inquiries are issued to this code or standard is shown on the copyright page. All technical inquiries must be submitted in writing to the staff secretary. Additional procedures for inquiries may be listed within.

ISBN 0-7918-2730-5



9 780791 827307



MO3001